

READ ME FIRST

CLASSIC ROOF

ERECTION MANUAL

**DUE TO THE PROCESS OF CONTINUOUS IMPROVEMENT,
THE PRODUCTS AND PROCEDURES IN THIS MANUAL ARE
SUBJECT TO CHANGE WITHOUT NOTICE**

Part #H8201

TABLE OF CONTENTS

TABLE OF CONTENTS	2
1.0 GENERAL INFORMATION	3
1.1 Receiving Materials & Filing Claims	3
1.2 Handling Materials.....	4
1.3 Storing Materials.....	5
1.4 Lifting/Handling Panels.....	6
1.5 Placing Panel Bundles on the Roof.....	7
1.6 How To Use This Manual	8
1.7 Proper Fastener Installation	9
1.8 Panel Preparation.....	10
1.9 Safety First	11
2.0 FASTENERS AND MASTICS REQ'D FOR INSTALLATION	12
2.1 General	12
3.0 INSTALLATION OF CLASSIC ROOF	14
3.1 Starting Layout	14
3.2 Mastic Installation Tips	15
3.3 Insulation	16
3.4 Sculptured Eave Trim.....	17
3.5 Panel/Fastener Diagram	18
3.6 Start/Finish Dimensions	19
3.7 Panel Erection at Low Eave	20
3.8 Panel Erection at Side Lap.....	21
3.9 Panel Splice Detail	22
3.10 Die-Formed Ridge Cap Installation	23
4.0 TRIM INSTALLATION	24
4.1 Trim Lap Details for Gutter, Rake, and Rake Parapet Trim	25
4.2 Trim Lap Details for High Eave & High Eave Parapet Trim	26
4.3 Low Eave Flash	27
4.4 Rake Trim at Corner Without Gutter.....	28
4.5 Gutter and Gutter Bracket Installation	29
4.6 Rake Trim at Corner With Gutter (Outside Corner).....	30
4.7 Rake Trim Installation.....	31
4.8 Rake Trim Termination at High Eave or Ridge	32
4.9 Peak Box Installation at Ridge Cap.....	33
4.10 Press-Broke Ridge Cap Installation at Peak Box.....	34
4.11 Press-Broke Ridge Cap Lap Detail	35
4.12 High Eave Trim Installation	36
4.13 Rake Parapet Trim Installation, With and Without Gutter	37
4.14 Rake Parapet Trim Termination at Die-Formed Ridge Cap.....	38
4.15 Rake Parapet Trim Termination at Press-Broke Ridge Cap	39
4.16 High Eave Parapet Trim Installation.....	40

1.0 GENERAL INFORMATION

1.1 RECEIVING MATERIALS & FILING CLAIMS

- Check shipment against delivery tickets during unloading.
- Note any damage or discrepancies on the delivery tickets before signing as receiver.
- Metal Building Supplier is not responsible for carrier damage or discrepancies not noted on the delivery tickets.
- Metal Building Supplier is not responsible for items accepted in questionable condition.
- Upon acceptance of shipment(s), the contractor is responsible for the proper storage and handling of materials as described in this manual.
- Metal Building Supplier is not responsible for injury, damage, or loss as a result of improper storage and/or handling.
- **All claims must be filed with Metal Building Supplier's Quality Services Representative prior to any field modifications or purchases that may result in a charge to Metal Building Supplier.**
- **This building is designed, manufactured, and delivered in accordance with the 2006 LOW RISE BUILDING SYSTEMS MANUAL as published by M.B.M.A.. Consult the information in the "COMMON INDUSTRY PRACTICES" section.**

1.2 **HANDLING MATERIALS**

Classic Roof panels are rolled and banded flat with a cover panel placed top and bottom.

Panel bundle weight can be found on the i.d. tag at low end of each bundle. Maximum weight is 4300# or 100 panels.

Bundles up to 25 feet can be handled using a forklift. Forks must be spaced a minimum of five feet apart.

Bundles over 25 feet should be handled with a crane using a spreader bar and nylon slings. Lifting should occur at center of gravity.

Locate slings at 1/4 of the length of the panel from each end of the bundle.

Trim crates/boxes are to be handled the same as panel bundles.

STEEL CHOKERS/SLINGS, CABLES OR CHAINS SHALL NOT BE USED.

1.3 STORING MATERIALS

Panel and trim bundles / crates should be blocked 12 inches above grade.

Elevate one end to allow moisture to drain.

Loosely cover with waterproof tarp to allow proper air circulation.

Inspect daily and dry if necessary.

Accessories must be kept dry and free of contamination. Store indoors if possible.

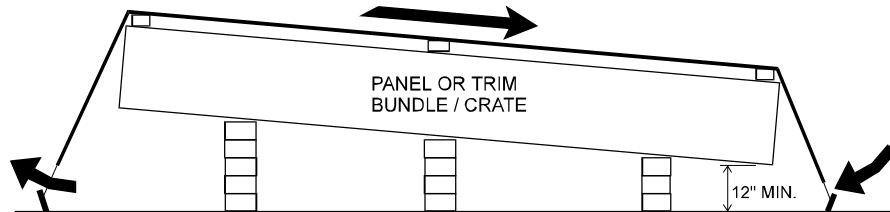

1.4 **LIFTING/HANDLING PANELS**

Lift and handle bundles as described earlier. Do not use any type of steel or cable slings.

Lift or carry single panels in a vertical position so as not to damage the seams.

Lift the panels at 1/4 points.



1.5 PLACING PANEL BUNDLES ON THE ROOF

Locate bundles on roof according to erection sequence.

Bundles should be located over primary structural frame lines, not in the middle of the bay.

Blocking shall be used, as shown, at panel bundle locations.

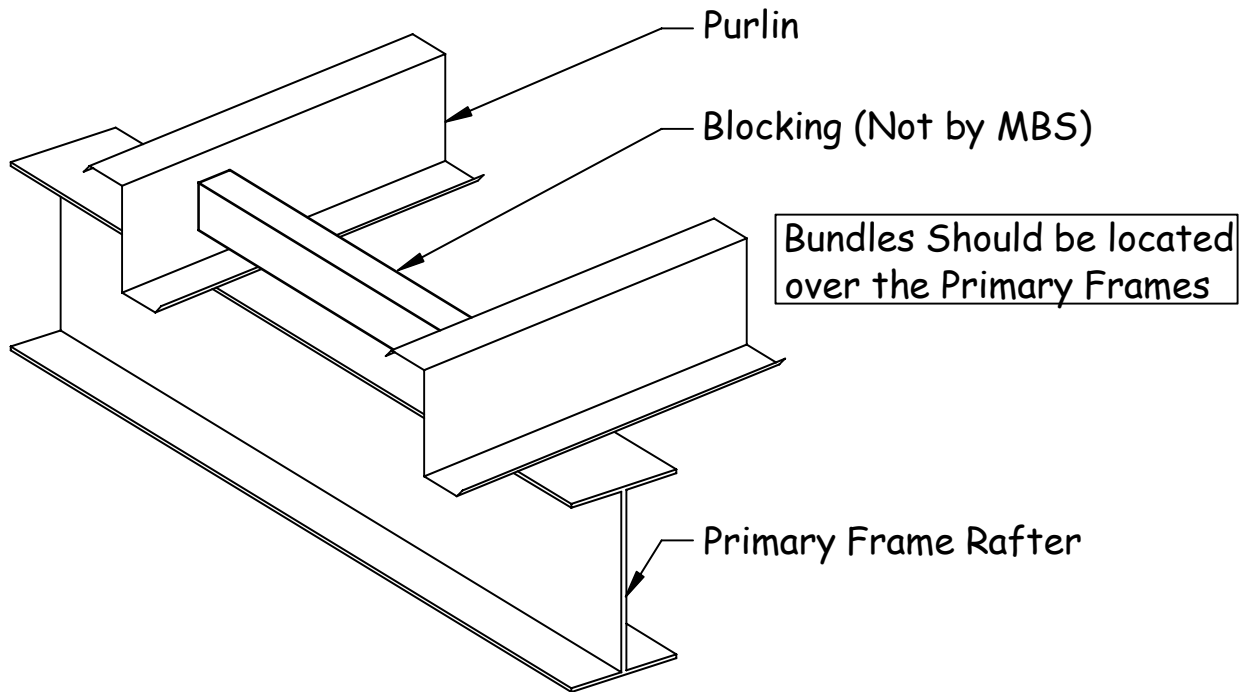

1.6 **HOW TO USE THIS MANUAL**

This erection manual is provided as the recommended procedure for the correct assembly of the Metal Building Supplier (MBS) Classic Roof System.

This manual is intended to be used in conjunction with the project's erection drawings to help plan and organize the installation of the (MBS) Classic Roof System. The erection drawings identify the applicable roof conditions and govern specific part arrangements. The instructions will help you identify parts, establish the installation sequence, demonstrate correct assembly, and point out any areas or procedures requiring special emphasis or attention. Before beginning erection, thoroughly familiarize yourself with this manual and project erection drawings.

The procedures contained in this manual are based upon standard conditions. If your project contains other than standard conditions, refer to your project erection drawings. **In the case of conflict between this installation manual and the erection drawings, the erection drawings will take precedence.**

The procedures contained in this manual are believed to be reliable however, Metal Building Supplier is not responsible for injury, damage, or failure due to the misapplication of these procedures, improper erection techniques, or negligence.

DUE TO THE PROCESS OF CONTINUOUS IMPROVEMENT, THE PRODUCTS AND PROCEDURES CONTAINED IN THIS MANUAL ARE SUBJECT TO CHANGE WITHOUT NOTICE.

“COMMON SENSE RULES” NEED TO BE APPLIED DURING THE INSTALLATION OF THIS ROOF SYSTEM TO INSURE THAT WEATHER-TIGHT CONDITIONS HAVE BEEN ACHIEVED.

The (MBS) Classic Roof System can be erected on many different types of construction. However, for this manual we have assumed this roof system will be erected on a new pre-engineered metal building.

1.7 PROPER FASTENER INSTALLATION

Refer to section 2.0 or the project erection drawings for fastener schedule

RECOMMENDED TOOL TYPES:

- 2000 - 2500 rpm screw gun with torque adjustable clutch
- Manual or electric rivet tool
- 6-7 amp or higher rated tools

DO NOT USE IMPACTING TOOLS

To assure proper voltage to the tool, extension cords should be checked for proper wire size/chord length.

- 16 gage wire, maximum chord length = 100'

- 14 gage wire, maximum chord length = 200'

- 12 gage wire, maximum chord length = 300'

DRIVING TIPS:

Drive fasteners perpendicular to panel surface.

Compress the insulation at fastener locations with one hand while driving the fastener with the other. This will help keep the panel flat and prevent the fastener from "walking".

Excessive pressure can cause drill point failure. Let the fastener do the work.

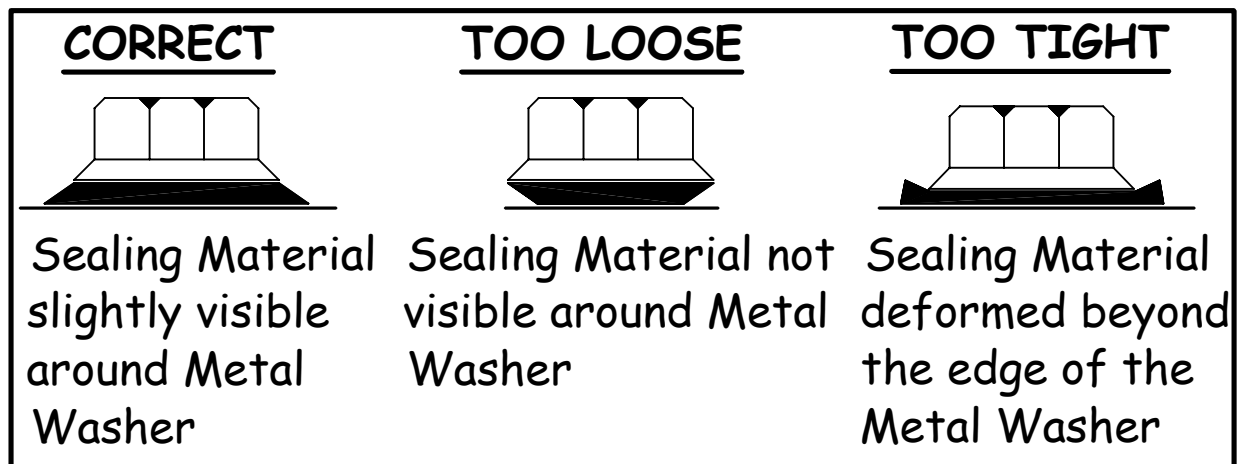

1.8 PANEL PREPARATION

(MBS) RECOMMENDS PRE-DRILLING SIDELAP JOINTS, WHICH IN MANY CASES, WILL SPEED ERECTION AND MAKE A TIGHT JOINT.

STEP 1: Stack the panels with the ends flush on a level place on the ground in piles not exceeding 10 panels. Then place small wooden blocks under the side lapping edge of the stack of the panels to hold them at the correct height and position while drilling the screw holes. Hold the panels tightly together at each end with "Vise Grip Pliers". Carefully mark the positions for sidelap fasteners on the top of the **HIGH** rib. Fasteners should be located **"ON CENTER"** of the high rib as shown below.

STEP 2: Drill holes for "Stitch" screws (Use #1,-7/32"-15/64" drill-bit) on the top sheet of the sidelap. Be sure that the panels are well nested before drilling.

WHEN USING OTHER TYPE FASTENERS, SIZE OF DRILL-BIT MAY CHANGE!

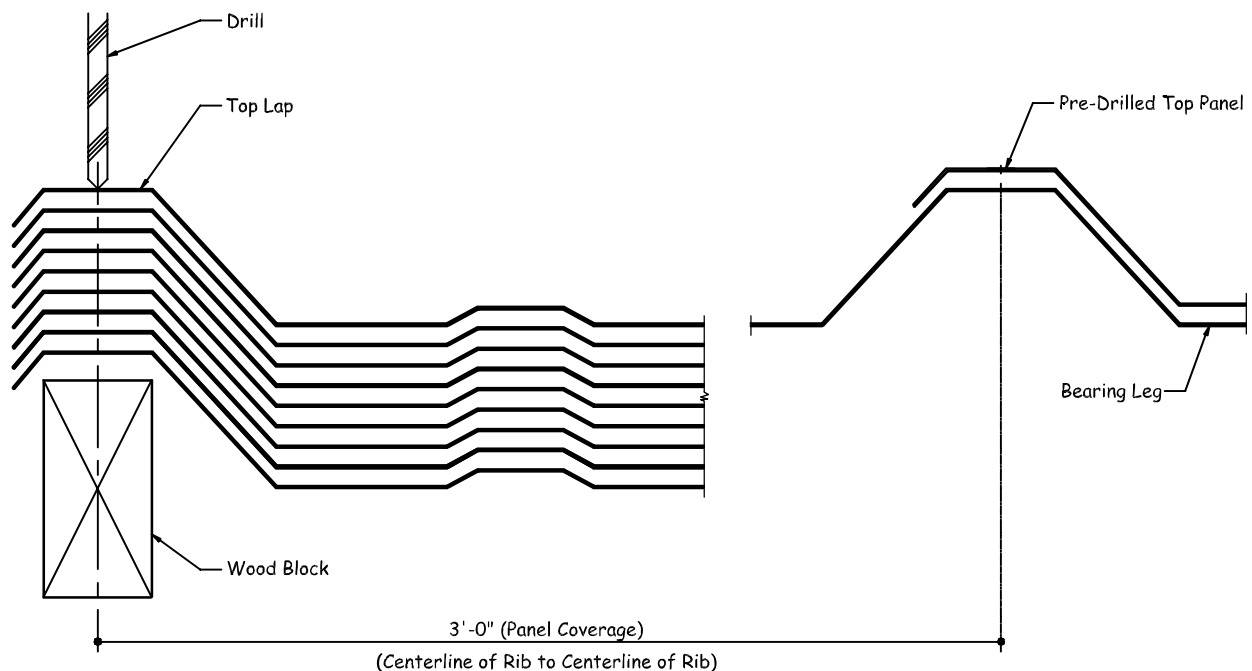

1.9 SAFETY FIRST

REGULATIONS SET FORTH BY THE OCCUPATIONAL SAFETY AND HEALTH ACT, LOCAL, STATE, AND/OR FEDERAL AGENCIES SHOULD BE ADHERED TO AT ALL TIMES. METAL BUILDING SUPPLIER IS NOT RESPONSIBLE FOR INJURY, DAMAGE, OR FAILURE, WHICH MAY BE THE RESULT FROM FAILING TO MEET ANY OF THESE REGULATIONS.

EXTREME CAUTION SHOULD BE EXERCISED WHEN WALKING ON ROOF PANELS:



OILS USED DURING THE ROLL FORMING PROCESS AND/OR NATURAL MOISTURE MAY CAUSE THE PANELS TO BECOME SLIPPERY



DO NOT STEP ON PANELS WITH CREASED EDGES
DO NOT STEP ON OR NEAR EDGE OF PANEL
DO NOT STEP WITHIN 5 FEET OF PANEL END

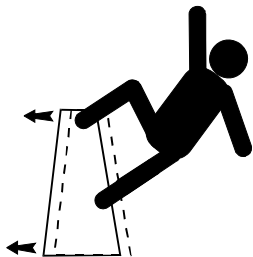

DO NOT USE LOOSE PANELS AS WORK PLATFORMS
DO NOT WALK ON UNSECURED PANELS
SECURE ALL LOOSE PANELS AT END OF DAY

USE EXTRA CARE WHEN WORKING ON STEEP SLOPES

IN COMPLIANCE WITH THE HAZARD COMMUNICATION RULE 1910:1200, MATERIAL SAFETY DATA SHEETS ARE AVAILABLE FOR YOUR USE AND SAFETY. IF REQUESTED, THESE DATA SHEETS SHOULD BE MADE AVAILABLE TO ALL PERSONNEL THAT COME IN CONTACT WITH THESE PRODUCTS. THESE DATA SHEETS WILL GIVE YOU THE NECESSARY INFORMATION TO PROPERLY HANDLE SUCH MATERIALS AND WHAT TO DO IN CASE OF EMERGENCY.

2.0 **FASTENERS AND MASTICS** **REQ'D FOR INSTALLATION**







2.1 **GENERAL**

This page and the following page show the fasteners, mastics, and tube caulks required for installation of the (MBS) Classic Roof System.

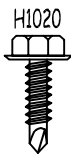
Because of the many variations in job conditions, it is important that you review the job conditions to identify the required parts for your job.

Review the erection drawings for any special parts, or parts that are different from what is shown in this section. If there are discrepancies, the erection drawings will take precedence.

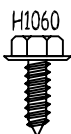
For proper sealing and fastening, and to help ensure proper roof performance, the correct parts must be used. Do not use parts other than those specified in this manual or on the erection drawings.

FASTENER	SPECIFICATIONS	USAGE
 <p>H1020</p>	<p>SELF-DRILLING SCREW No. 1/4-14x1 1/4" TEK 3 W/O Washer 3/8" HEAD Recommended Tool Types: -2000 RPM; Torque Adjustable Clutch -4 Amp or Higher Rated Tools -DO NOT use Impacting Tools</p>	Used to attach rake angle to purlins.
 <p>H1030</p>	<p>SELF-DRILLING SCREW No. 12-14x1 1/4" TEK 2 W/ Sealing Washer LONG LIFE FASTENER - 3/8" HEAD Recommended Tool Types: -2000-2500 RPM; Torque Adjustable Clutch -DO NOT use Impacting Tools</p>	Used attach roof panel, roof flashing and light gage parts. Maximum Insulation thickness is 6".
 <p>H1035</p>	<p>SELF-DRILLING SCREW No. 12-14x1 1/2" TEK 2 W/ Sealing Washer LONG LIFE FASTENER - 3/8" HEAD Recommended Tool Types: -2000-2500 RPM; Torque Adjustable Clutch -DO NOT use Impacting Tools</p>	Used attach roof panel, roof flashing and light gage parts. Maximum Insulation thickness is 6".
 <p>H1050</p>	<p>SELF-TAPPING SCREW No. 12-14x 3/4" Sharp Point W/ Sealing Washer LONG LIFE FASTENER - 3/8" HEAD Recommended Tool Types: -2000 RPM; Torque Adjustable Clutch -DO NOT use Impacting Tools</p>	Used attach light gage roof trim end laps and trim to roof panels.
 <p>H1060</p>	<p>SELF-TAPPING SCREW No. 12-14x 3/4" Sharp Point W/O Washer 5/16" HEAD Recommended Tool Types: -2000 RPM; Torque Adjustable Clutch -DO NOT use Impacting Tools</p>	Used to attach light gage wall trim end laps and trim to wall panels.
 <p>H1100</p>	<p>POP RIVET 1/8" Blind Pop Rivet Recommended Tool Types: -Manual or Electric Rivet Tool -DO NOT use Impacting Tools</p>	Used at trim laps, corner caps, and attaching lightgage material to siding where stitch screws can't be used.

TAPE MASTIC

Isobutylene Tripolymer
50'-0" Roll

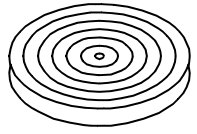

Width = 3/4"
Thickness = 1/8"

Part No. H3000

TAPE MASTIC

Isobutylene Tripolymer
20'-0" Roll

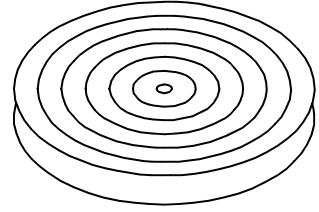

Width = 2 1/4"
Thickness = 3/16"

Part No. H3020

8" PRECUT MASTIC

(5) Strips Per Sheet
Protective Paper Backing

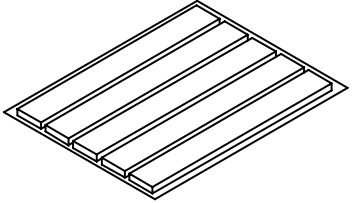

Length = 8"
Width = 1"
Thickness = 1/4"

Part No. H3041

TAPE MASTIC

Isobutylene Tripolymer
50'-0" Roll

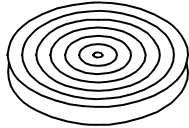

Width = 1/2"
Thickness = 3/32"

Part No. H3010

BUTYL TUBE CAULK

Roof Applications

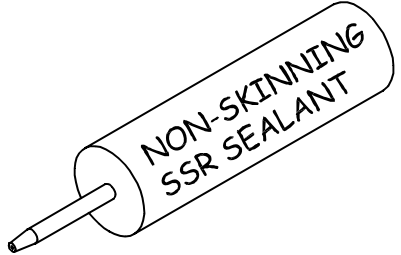

Part No. H3151

POLYURETHANE TUBE CAULK

For Use At Trim Laps

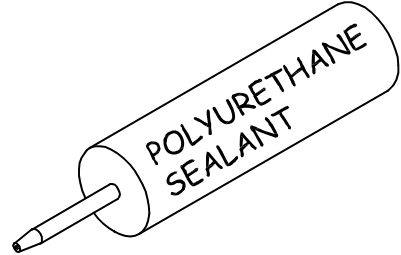

Part No. H3152

3.0 INSTALLATION OF CLASSIC ROOF

3.1 STARTING LAYOUT

The roof panels are designed to, and will lay left to right or right to left.

Panel installation must begin at the low eave corner and be sequenced as shown.

Both sides of the ridge should be erected simultaneously to ensure proper alignment of panel ribs and positioning of the die-formed ridge cap.

ERECTOR NOTE: SOME DETAILS CONTAINED WITHIN THIS MANUAL SHOW CONDITION AS THOUGH THE PANELS ARE BEING ERECTED FROM LEFT-TO-RIGHT. THE PANELS CAN ALSO BE ERECTED FROM RIGHT-TO-LEFT, AND THE CONDITIONS ARE SIMILAR TO THE POINT THAT THE SAME DETAILS CAN BE UTILIZED WITHOUT ANY PROBLEMS.

WARNING: PENCIL LEAD AND MARKER WILL CAUSE GALVALUME PANELS AND TRIM PIECES TO RUST. DO NOT USE THESE TO MARK ON PARTS.

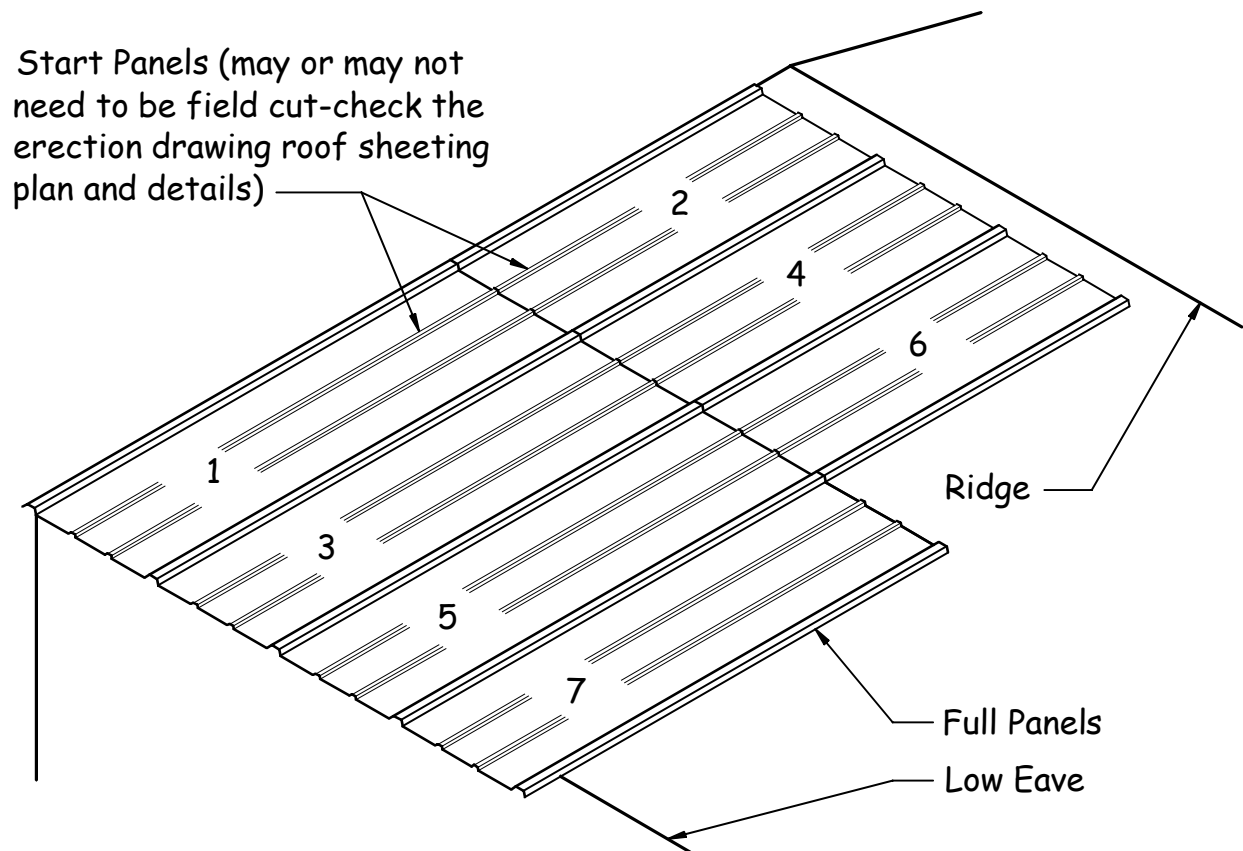

NOTE: Both sides of the ridge should be erected simultaneously to ensure both proper alignment of panels and positioning of the DIE-FORMED ridge cap.

3.2 **MASTIC INSTALLATION TIPS**

Apply the tape mastic only to clean dry surfaces.

Roll the mastic out to arm length.

Press the mastic firmly in place making sure it is tightly formed to all bends.

Remove the paper backing only when ready to install the top component.

Splice the mastic with a 2" lap.

Press the lapped pieces of mastic firmly together to form a single thickness.

DO NOT STRETCH TAPE MASTIC ACROSS THE CORNERS. THIS WILL DECREASE THE THICKNESS WHERE IT IS NEEDED THE MOST.

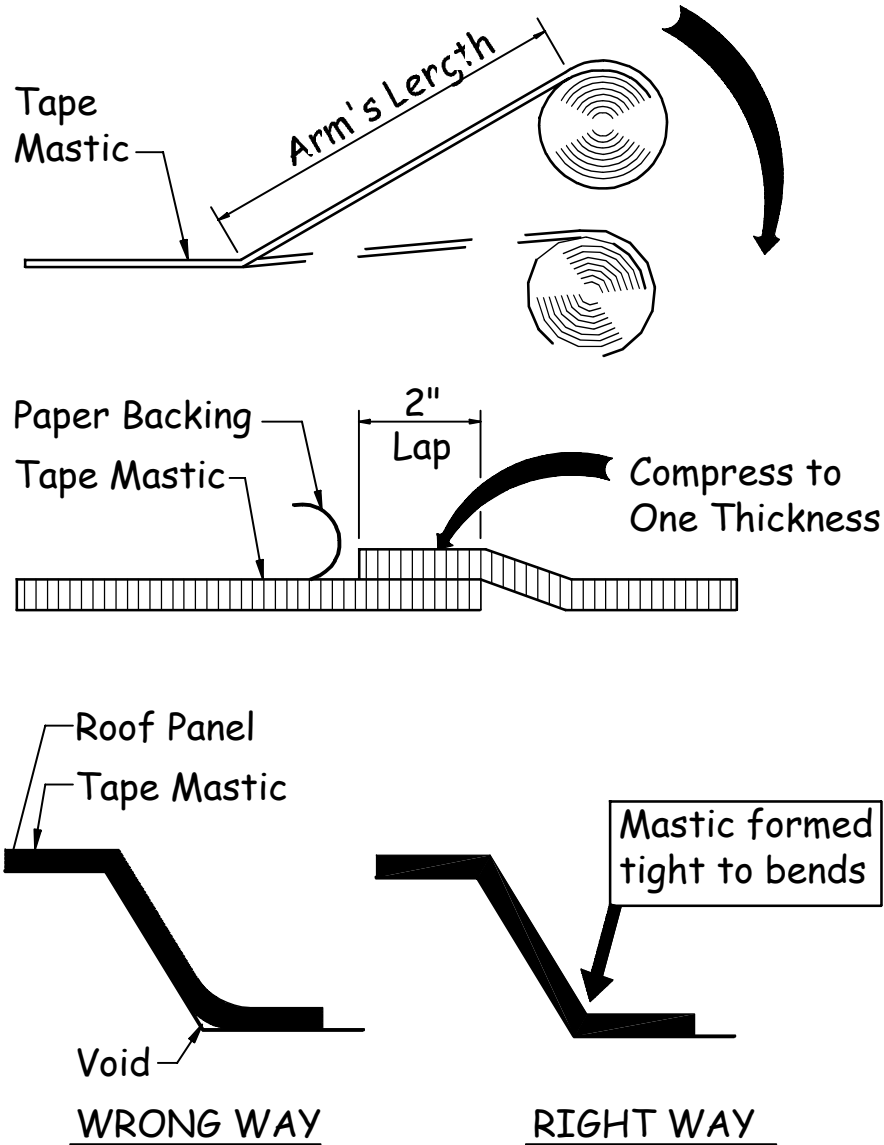

3.3 INSULATION

Install the (optional) insulation pan at the ridge, if required, prior to any roof panel installation. Do not attach at this time, the insulation screws will make the attachment. **DO NOT USE INSULATION PAN AS A WORK PLATFORM.**

Align the edge of the insulation with the building endwall steel line.

Pull the insulation toward the ridge / high eave so as to create a smooth appearance of the backing.

Consult the insulation manufacturer installation instructions for proper seaming and taping methods.

At the low eave, remove a 4" strip of insulation from the backing leaving a 4" strip of backing exposed.

Fold this strip of backing over the insulation batt creating a double vapor barrier.

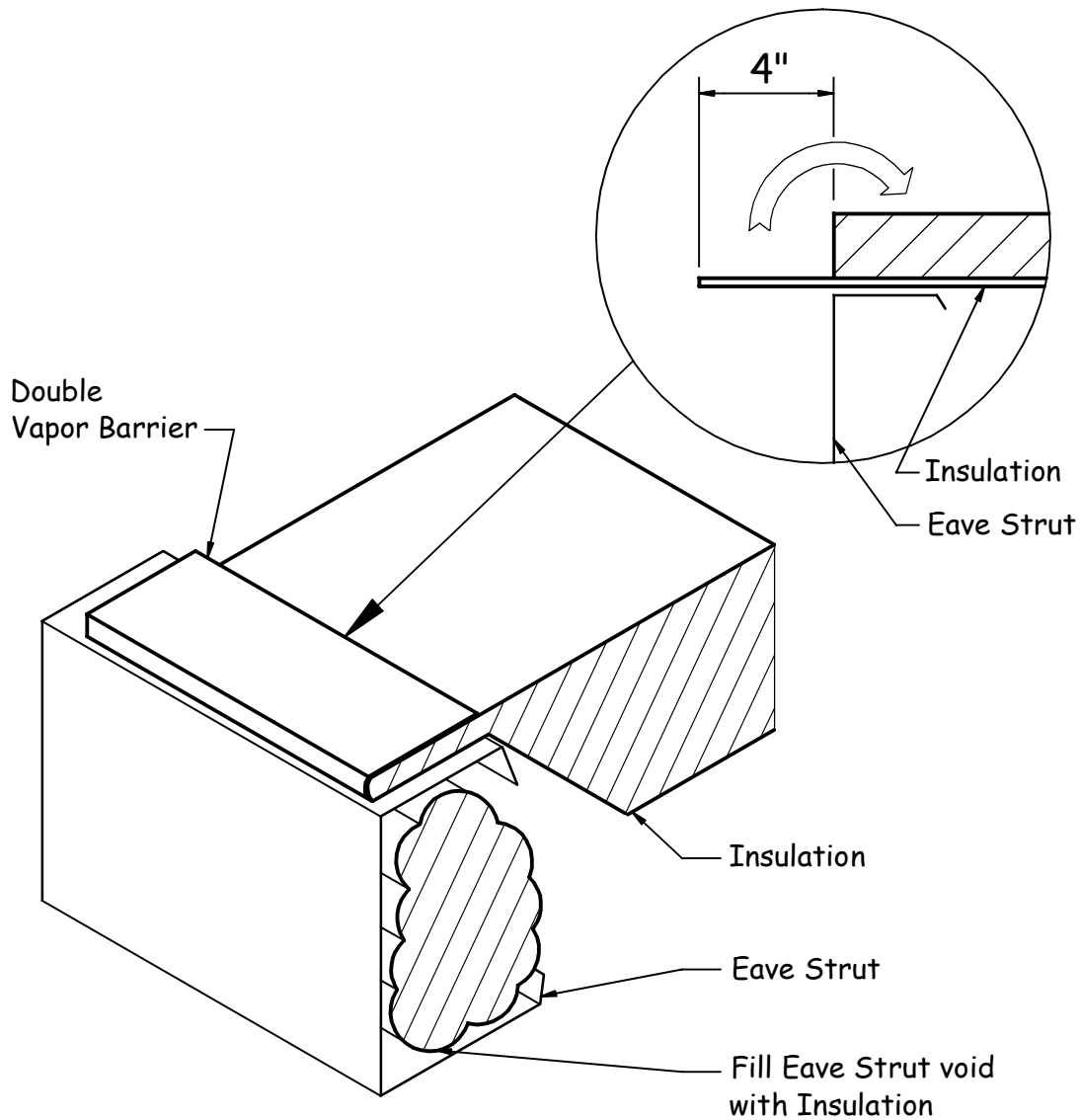

3.4 SCULPTURED EAVE TRIM

If your building has sculptured eave trim, the cap trim **must** be installed prior to the installation of roof insulation and roof panels.

After the eave member has been installed, place the cap trim (CTA__) flush with the end of the eave member. Use the overhang dimensions per the roof slope noted in the following detail, then fasten with (1) **self-drilling screw (H1020)** at each end.

When using masonry wall or open wall conditions, use the following dimensions from face of masonry or steel line:

- 1 3/4" @ .5:12
- 2 1/4" @ 1:12
- 2 7/8" @ 2:12
- 3 5/16" @ 3:12
- 3 13/16" @ 4:12

See the erection drawing details for sculptured eave trim installation instructions.

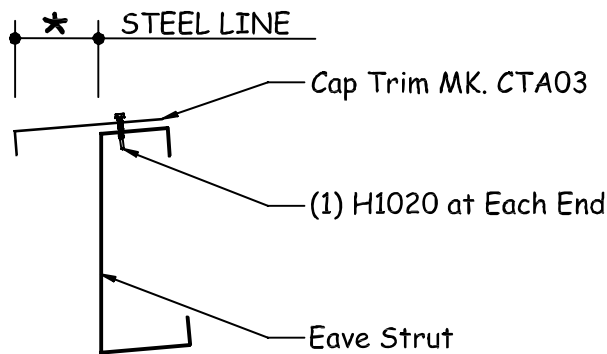

NOTE: See the Erection Drawing Roof Line Trim Details for Sculptured Eave Trim Installation Instructions

- * 3" at .5:12 Roof Slope

- * 3 1/2" at 1:12 Roof Slope

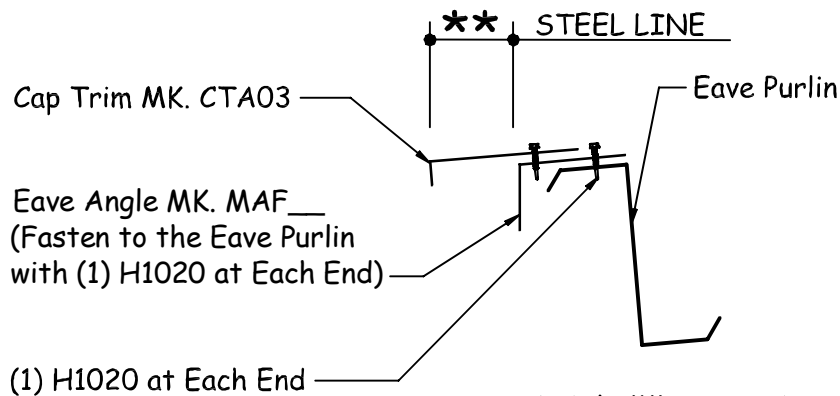

- ** 4 1/8" at 2:12 Roof Slope

- ** 4 5/8" at 3:12 Roof Slope

- ** 5 1/8" at 4:12 Roof Slope

3.5 PANEL/FASTENER DIAGRAM

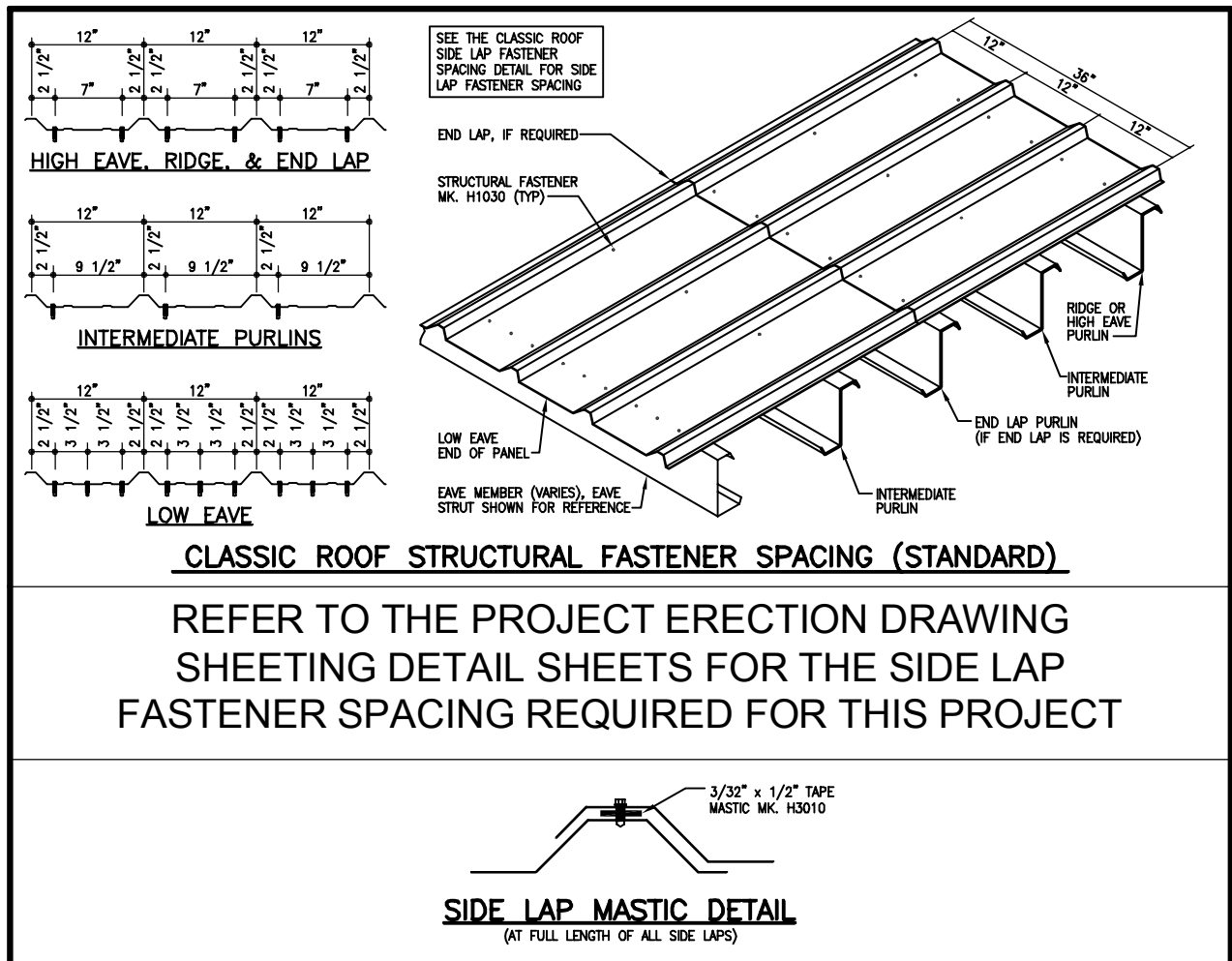

3.6 START/FINISH DIMENSIONS

IMPORTANT! Note the minimum and maximum panel rib locations from the steel line. (Condition "A" and condition "B")

Condition "A" and "B" could occur at either the start or the finish end. These rib locations must

be maintained for the rake trim to fit properly. Field cutting of panel(s) may be required.

Refer to your project erection drawings "**ROOF SHEETING PLAN**" for specific start and finish panel rib locations.

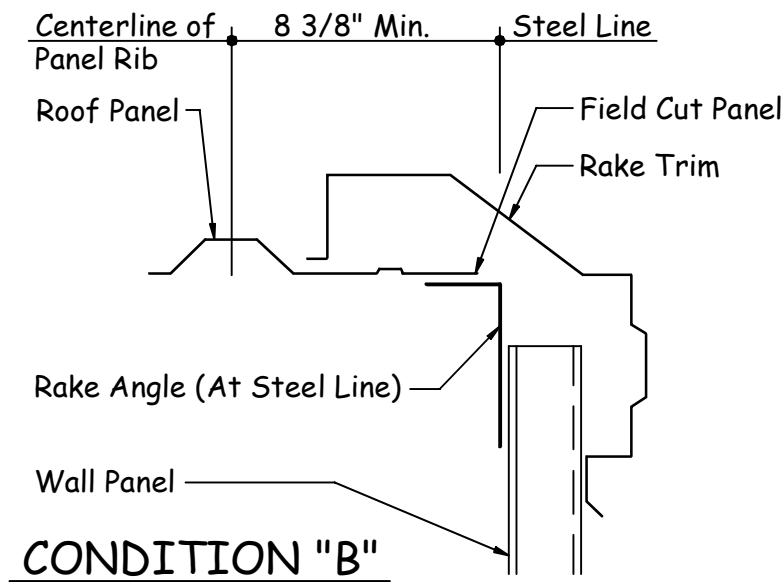
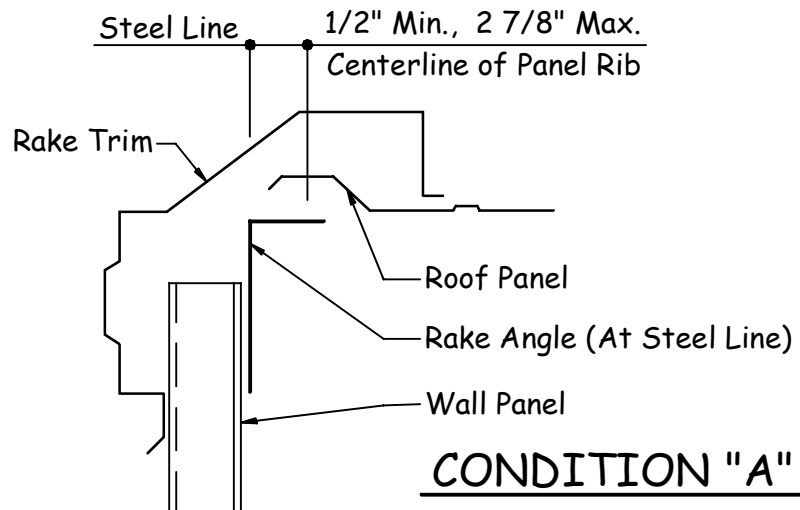

3.7 PANEL ERECTION AT LOW EAVE

Apply **3/4" tape mastic (H3000)** to the top & bottom of the insulation vapor barrier, the full length of the roof.

Position the **inside rubber closure (H3410)** directly over the mastic and apply **3/4" tape mastic (H3000)** to the top side of the closure.

Check your project erection drawings for proper roof panel start and **overhang dimensions**. Install a string line 1" from the end of the panel to help ensure proper panel installation.

Position the roof panel over the closure and set in place. **NOTE: The panel must be properly positioned before touching the mastic. Mastic cannot be reused.**

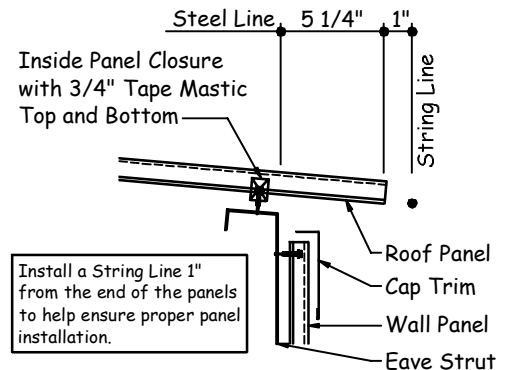
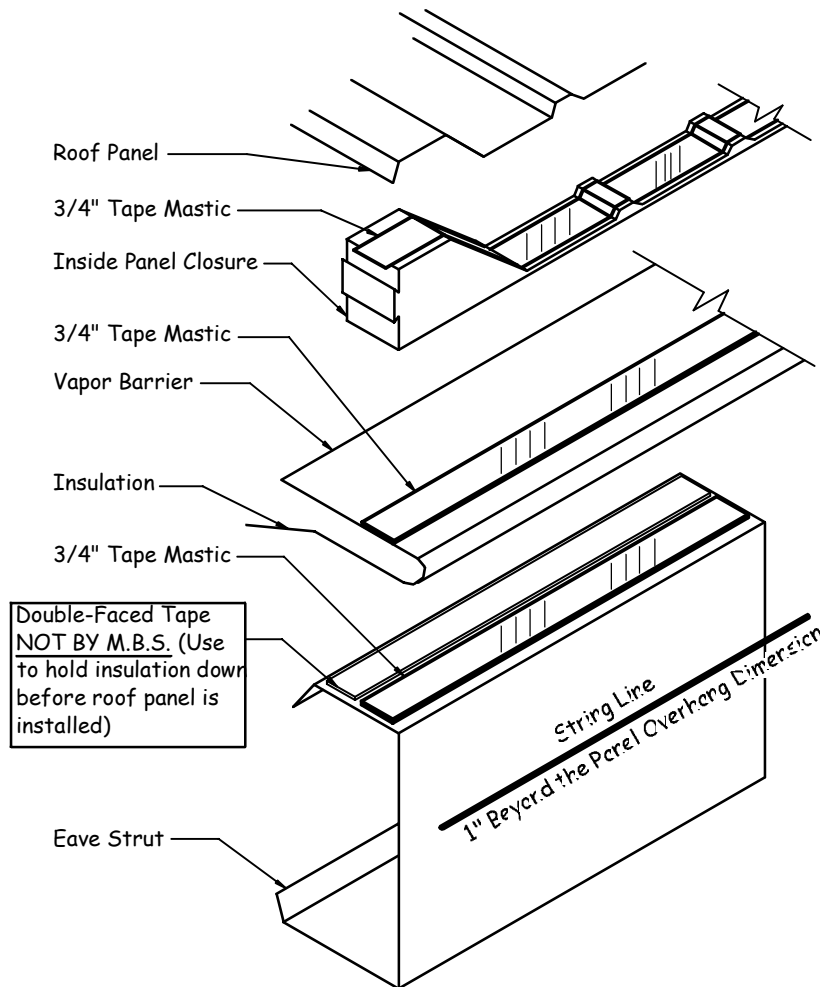

STD. EAVE DETAIL

NOTE: Verify the Roof Panel Overhang Dimension with the Erection Drawing Details

3.8 PANEL ERECTION AT SIDE LAP

1/2" sidelap tape mastic (H3010) must be applied to the bearing leg of the panel rib as shown to obtain a weathertight panel lap.

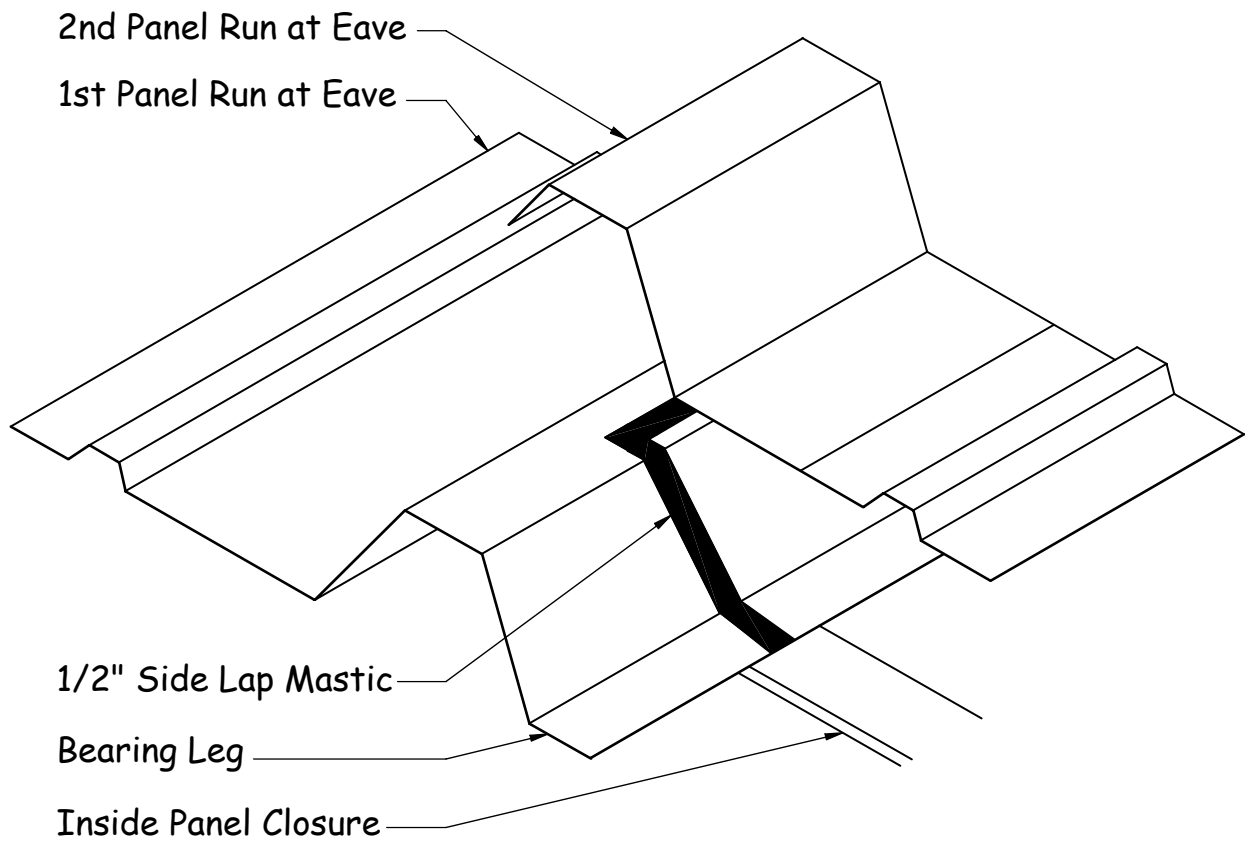

3.9 PANEL SPLICE DETAIL

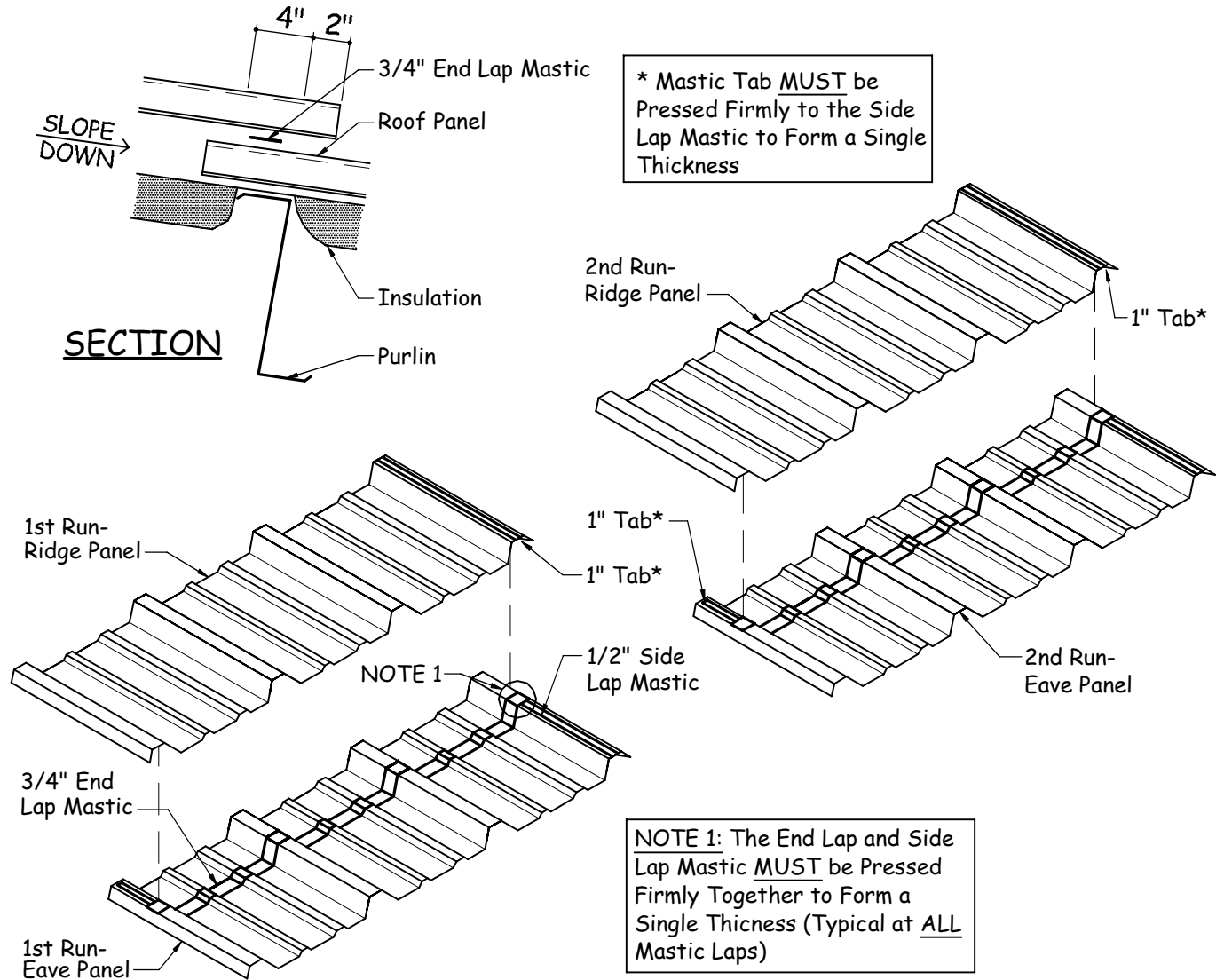

3.10 DIE-FORMED RIDGE CAP INSTALLATION

IMPORTANT NOTE: The panel ribs **MUST** be aligned across the ridge for proper fit-up of the die-formed ridge cap.

Fasten the ridge cap side laps with (6) self-tapping screws (H1050).

See the fastener diagram in section 3.5, or your project erection drawings for proper fastener placement.

If your roof has press-broke ridge cap, go to section 4.11 for installation instructions

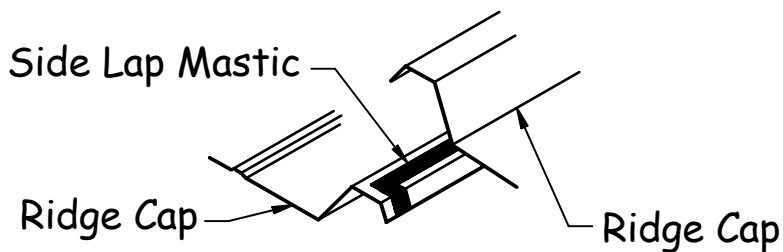
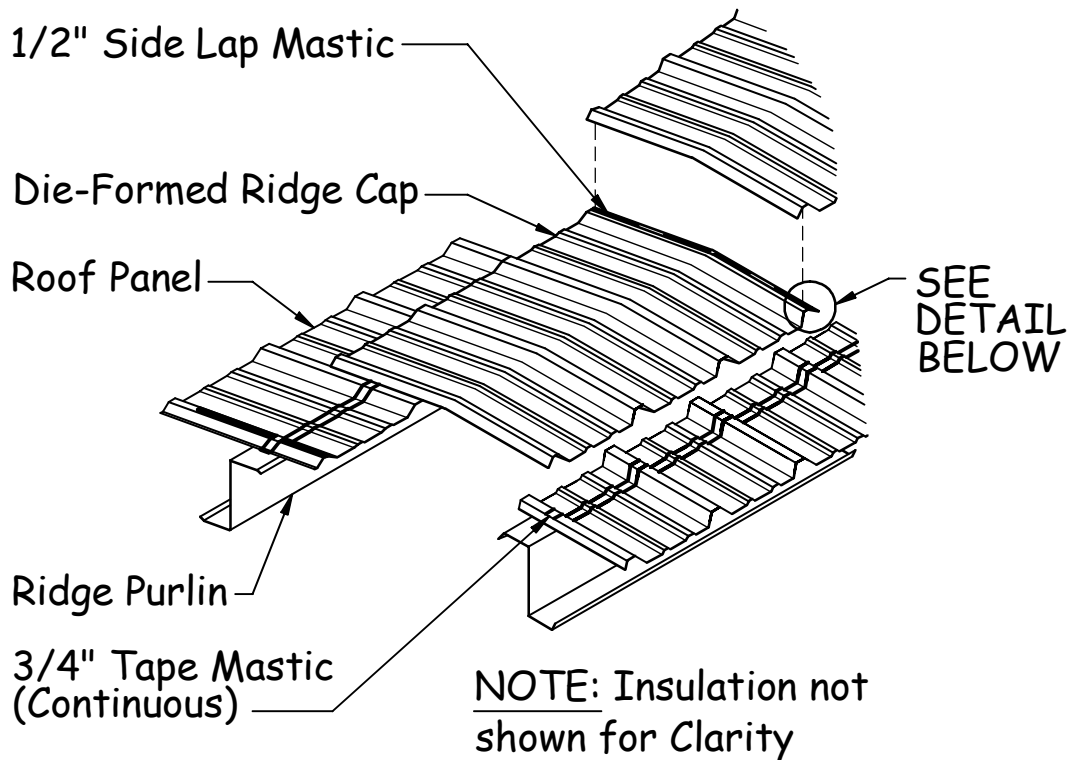

RIDGE CAP LAP MASTIC DETAIL

4.0 TRIM INSTALLATION

Begin installing trim at the back of the building working toward the front. This will “hide” the trim laps from direct view.

When lapping rake trim and rake parapet trim, the upper piece should overlap the lower piece. This will help prevent water from entering the building.

Panel cap trim (CTA__) must be installed prior to the installation of the low eave trim (see the detail below).

Some field cutting, trimming, and bending is required. Extreme care must be taken while performing any fieldwork so as to produce an attractive, weathertight condition.

NOTE: The wall panel (or whatever material is being on the walls) will need to be installed before the roof line trim can be installed.

The parts shown in the following sections are the “standard” trim profiles. It is a good idea to compare the part numbers in this manual with the erection drawing roof line trim details to verify the correct part numbers. In the case of conflict, the erection drawings will take precedence.

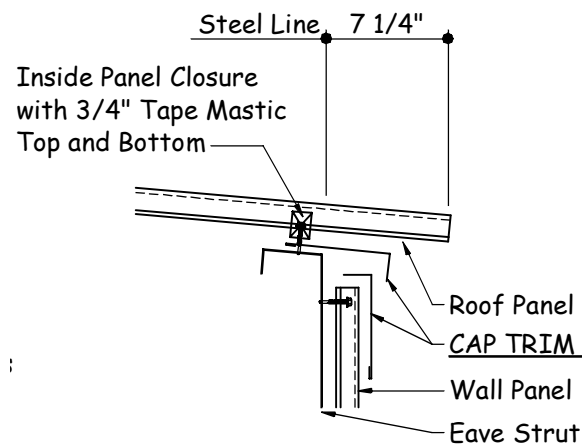

STD. SCULPTURED EAVE DETAIL

NOTE: Verify the Roof Panel Overhang Dimension with the Erection Drawing Details

4.1 TRIM LAP DETAILS FOR GUTTER, RAKE, AND RAKE PARAPET TRIM

GUTTER: Apply a continuous bead of **polyurethane tube caulk (H3152)** to the end of adjoining trim piece, lap 1", and fasten with 10 **pop rivets (H1100)**.

RAKE TRIM: Apply a continuous bead of **polyurethane tube caulk (H3152)** to the end of the adjoining trim piece and lap 1". Fasten with (5) trim-colored **self-tapping screws** and (5)

pop rivets (H1100). Always begin trim installation at the low eave working toward the high eave.

RAKE PARAPET TRIM: Apply a continuous bead of **polyurethane tube caulk (H3152)** to the end of the adjoining trim piece, lap 1" and fasten with (4) **self-tapping screws (H1050)** and (2) **pop rivets (H1100)**.

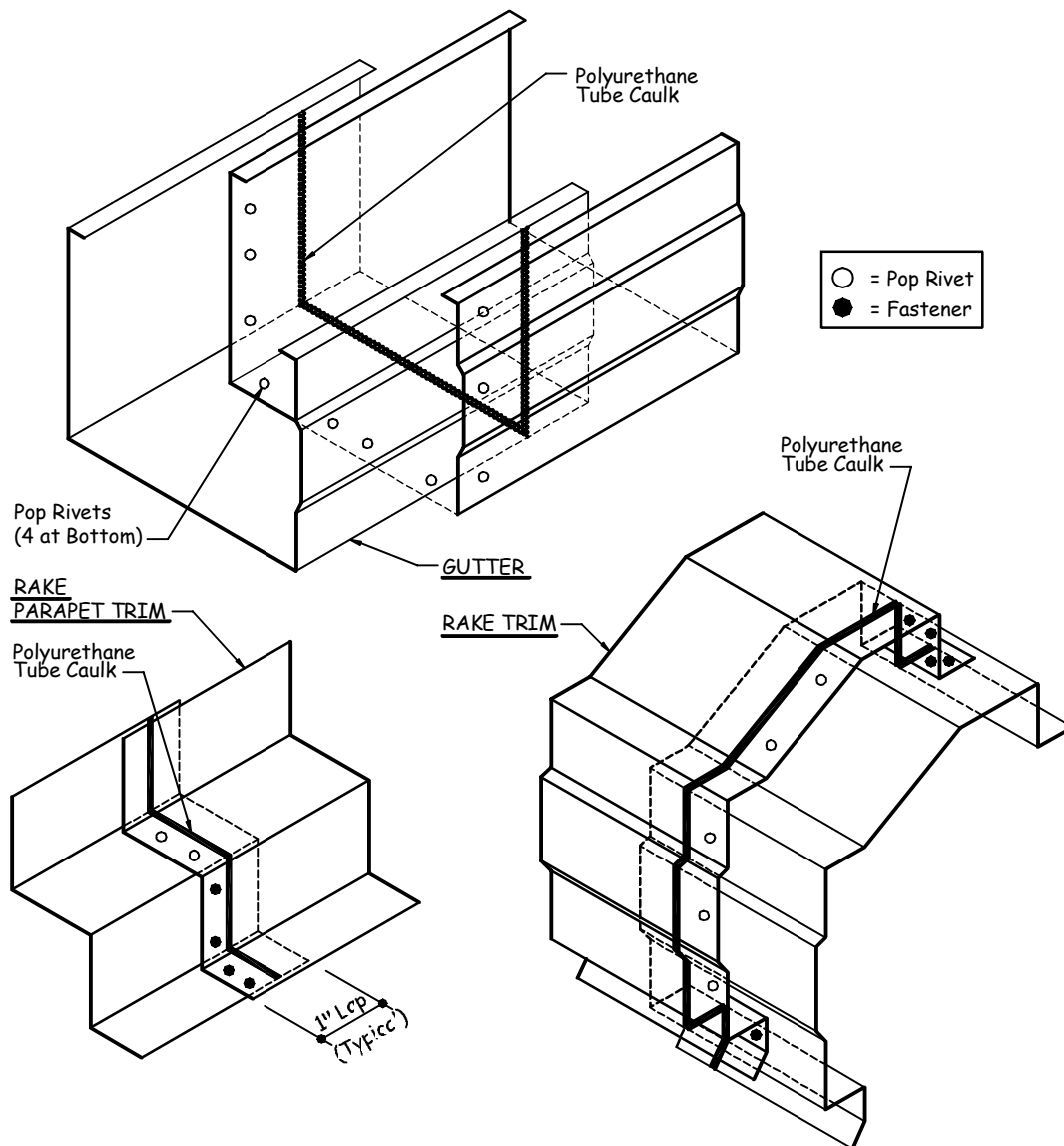

4.2 TRIM LAP DETAILS FOR HIGH EAVE & HIGH EAVE PARAPET TRIM

HIGH EAVE TRIM: Apply a continuous bead of polyurethane tube caulk (H3152) to the end of adjoining trim piece, lap 1" and fasten with (4) self-tapping screws (H1050) and (4) pop rivets.

HIGH EAVE PARAPET TRIM: Apply a continuous piece of 3/4" tape mastic (H3000) at the end of the installed trim piece. Position the adjoining trim piece on the top of the mastic and fasten with (7) self-tapping screws (H1050).

Apply a bead of polyurethane tube caulk (H3152) on top of the mastic.

SCULPTURED EAVE TRIM:

See erection drawing details for installation instructions.

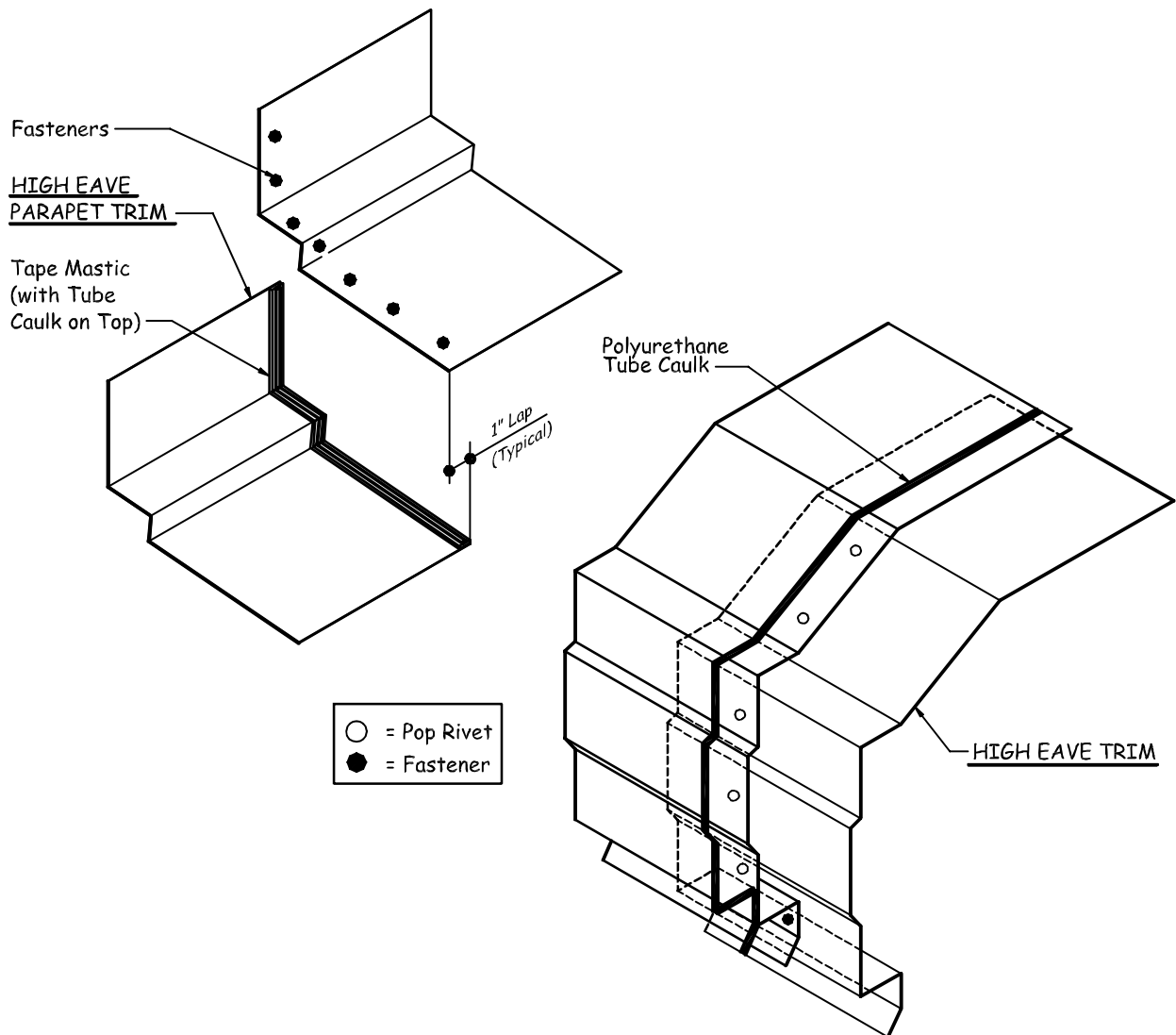

4.3 LOW EAVE FLASH

Prior to installing the eave flash, the cap trim must be installed, if supplied, reference erection drawing details and bill of materials for part. Do this by aligning the edge of the cap trim with edge of the corner trim. Fasten temporarily with (1) **pop rivet (H1100)** at each end.

Apply $\frac{3}{4}$ " **tape mastic (H3000)** to the upper leg of the eave flash. Align the edge of the eave

flash with the edge of the wall corner trim. Position the top leg tight to the bottom of the roof panel.

Fasten at ends and 12" on center with trim-colored **self-tapping screws (H1060)**.

Lap the trim 1", applying **polyurethane tube caulk (H3152)** between. Fasten with (1) trim-colored **self-tapping screw (H1060)**.

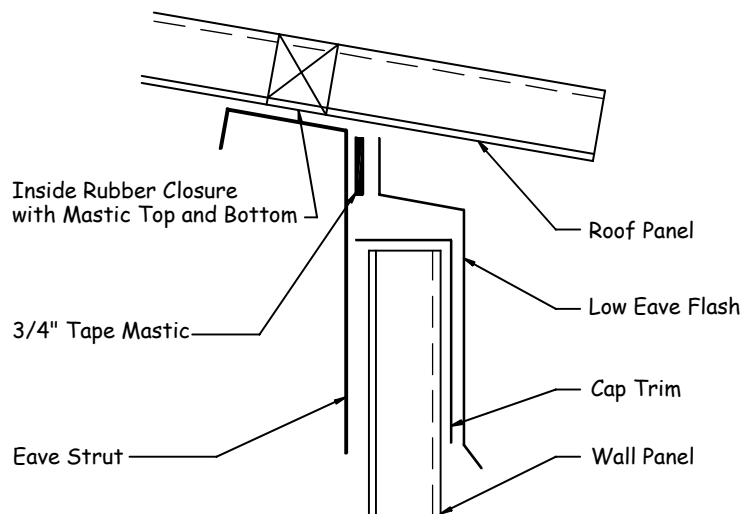

WALL SECTION

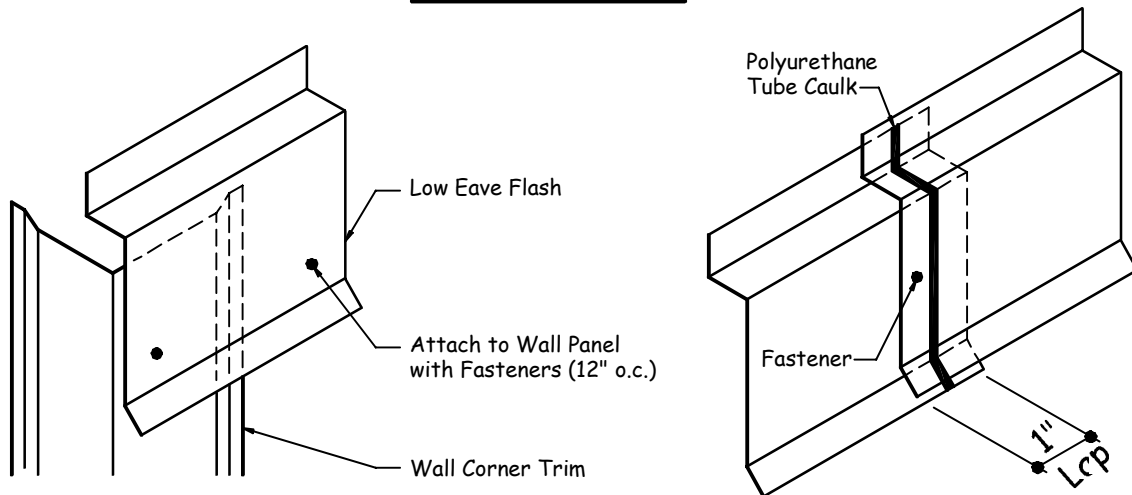

DETAIL AT WALL CORNER TRIM

LAP DETAIL

4.4 RAKE TRIM AT CORNER WITHOUT GUTTER

- RAKE TRIM PART NUMBERS
- RTA01 x 10'-1" RTA02 x 20'-2"

All parts must be positioned properly before touching the mastic to the roof panel. Mastic cannot be reused!

Before installing the rake trim, the **rake cap (RCA__)** must be installed and the **gutter end cap (H4000)** prepped. For the rake cap, apply **polyurethane tube caulk (H3152)** to the top and bottom surfaces and place it on the edge of the panel 1 1/2" from the edge of the gutter end cap (no fasteners required). Field cope the flat of the rake cap as required. Prep the gutter end cap by placing the **eave/rake cap (ERA01)** onto the back of the cap and fasten with (6) **pop rivets (H1100)** as shown below.

Apply continuous **2 1/4" tape mastic (H3020)** to the bottom of the horizontal leg of the rake trim (the leg that attaches to the roof panel).

Extend the low eave end of the rake trim flush with the low eave end of the roof panel. Fasten the rake trim to the roof panel with trim colored self-drilling **screws (H1030)** at 4" o/c. Fasten the rake trim to the **rake cap** with (4) trim colored self-tapping **screws (H1050)** and (2) **pop rivets (H1100)**. Cope the bottom vertical leg of the rake trim flush with the outside face of the wall corner trim.

For the installation of the prepped **gutter end cap (H4000)**, apply **polyurethane tube caulk (H3152)** to the outside perimeter (as shown below) and place it inside the rake trim with the flat edge of the gutter end cap flush with the end of the rake trim. Fasten the rake trim to the gutter end cap with (3) **pop rivets (H1100)**.

Rake Trim. Cope as shown. DO NOT Fasten the Rake Trim to the Wall Panel.

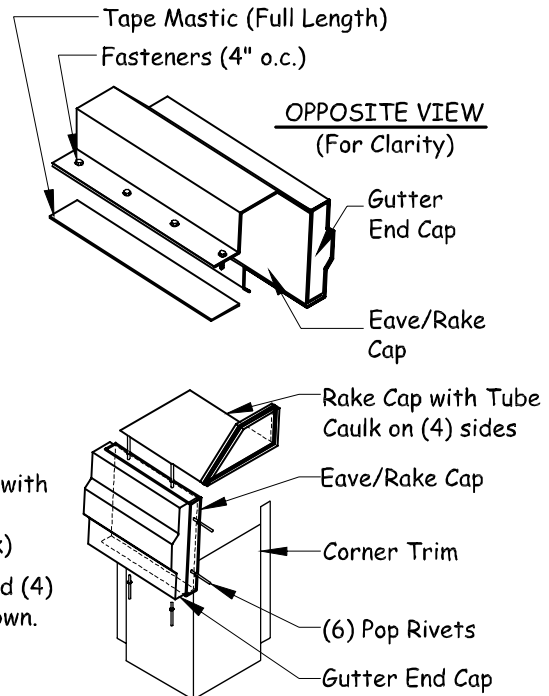
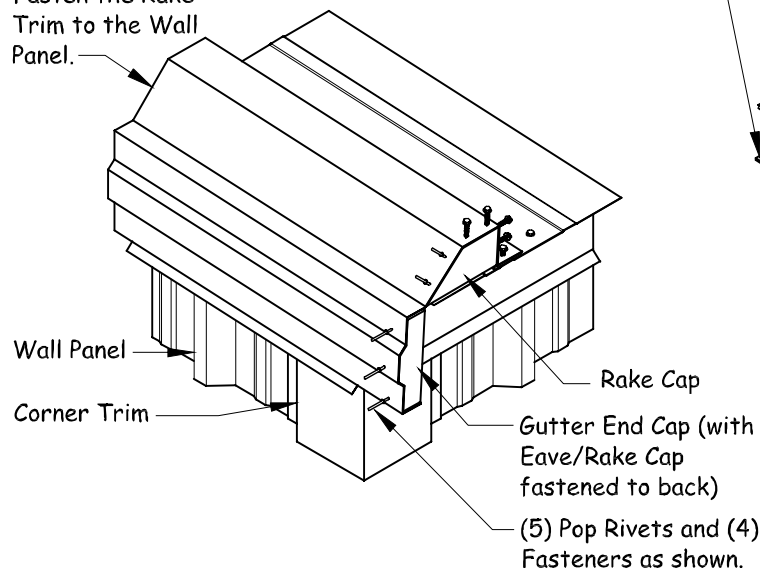

4.5 **GUTTER AND GUTTER BRACKET INSTALLATION**

Establish a string line 7" from end of the roof panel for proper gutter bracket alignment.

Apply 6" long tape mastic (H3000) to the end of the gutter bracket (H2190) directly under the pre-punched holes.

Fasten the bracket to the panel HIGH rib with (2) gutter bracket-colored self-tapping screws (H1050).

Apply 1/2" tape mastic (H3010) to the back lip of the gutter and then fasten the gutter to the roof panel with roof-colored self-tapping screws (H1050) at 12" on center. **NOTE: Clamping the gutter to the roof panel will allow for easier gutter installation.**

Attach the gutter to the bracket with (1) trim-colored self-tapping screw (H1050).

NOTE: The gutter bracket should be UNDER the lip of the gutter.

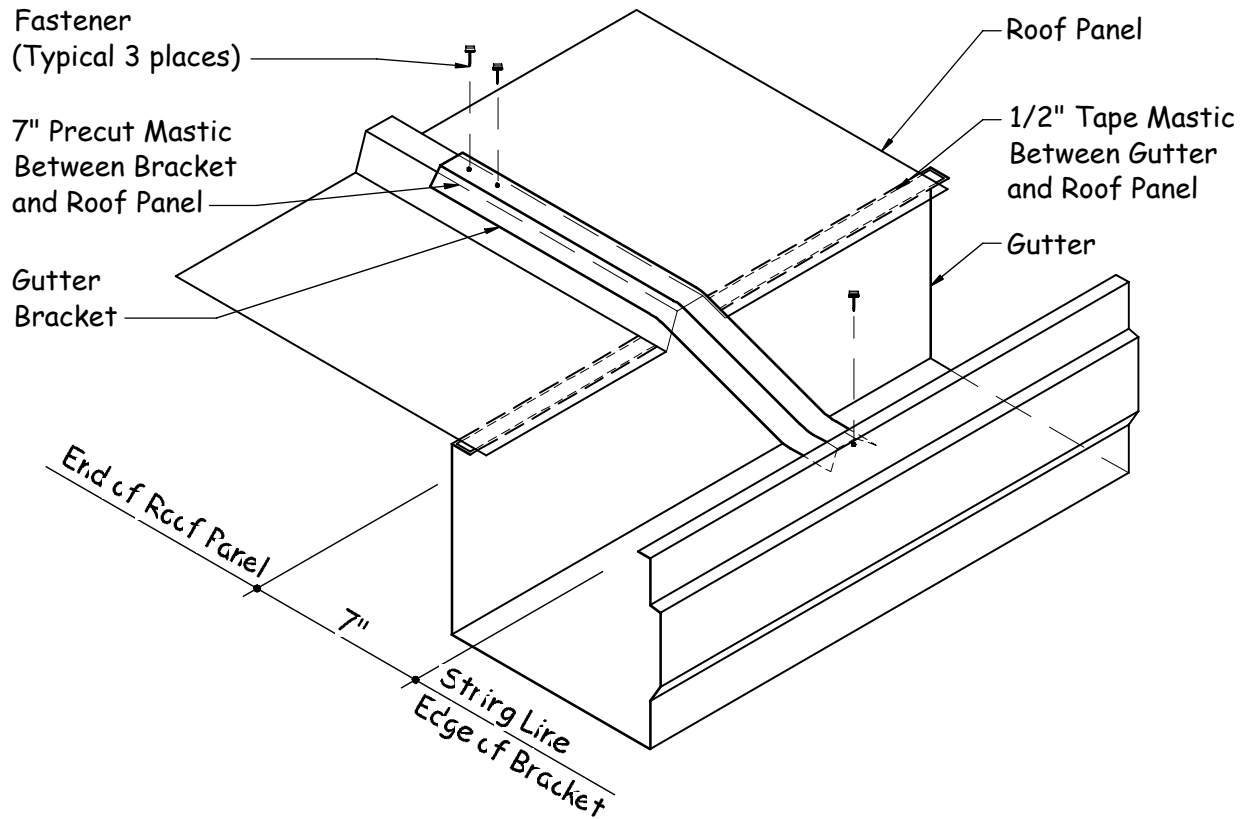

4.6 RAKE TRIM AT CORNER WITH GUTTER (OUTSIDE CORNER)

Extend the gutter 1" past the edge of the wall corner trim.

Apply a continuous bead of **polyurethane tube caulk (H3152)** around the perimeter of the **corner cap (H4000)** close to the inside edge.

Insert the corner cap into the gutter leaving 1/2" of the cap exposed on all sides.

Fasten with (6) **pop rivets (H1100)** at front and back only.

Fasten the **gutter/rake trim (GRA01)** piece to the wall corner trim with (2) trim-colored **self-**

tapping screws (H1050). Hold the trim piece tight to the back of and flush with the bottom of the gutter.

Apply **polyurethane tube caulk (H3152)** to the bottom of the **rake cap (*)** and place it on the gutter 1 1/2" from the edge of the plastic corner cap. **Fasteners are not required.**

(*) RAKE CAP PART NUMBERS:

RCA01-LEFT

RCA02-RIGHT

NOTE: The plastic corner cap, gutter rake trim, and rake cap must be installed before the rake trim is installed.

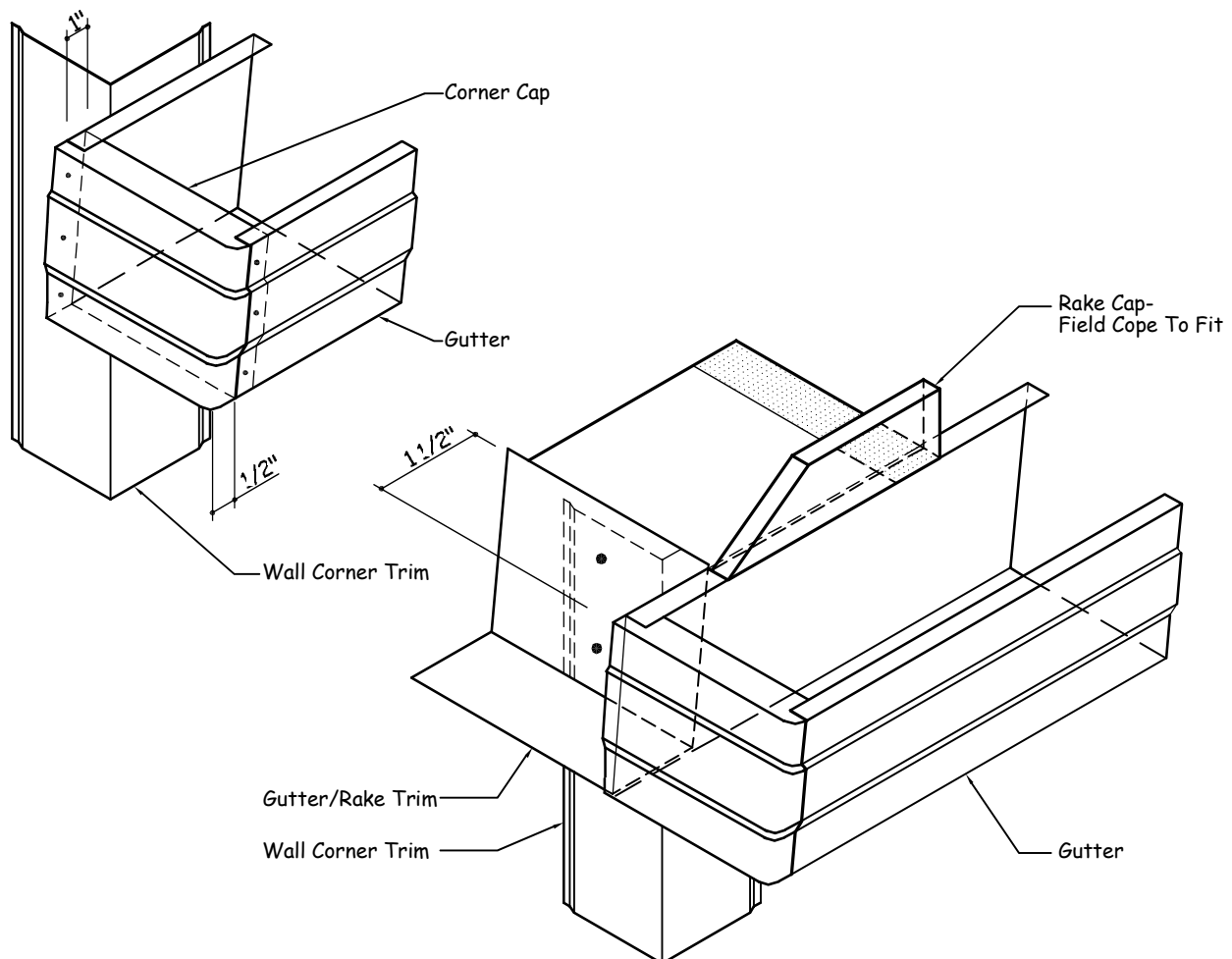

4.7 RAKE TRIM INSTALLATION

Apply continuous **2 1/4" tape mastic (H3020)** to the bottom leg of the rake trim.

RAKE TRIM PART NUMBERS:

RTA01 X 20'-2"

RTA02 X 10'-1"

ALL PARTS MUST BE PROPERLY POSITIONED BEFORE TOUCHING MASTIC TO ROOF PANEL. MASTIC CANNOT BE REUSED!

Hold the edge of the rake flash **1/2"** short of the face of the gutter as shown.

Fasten to the roof panel with trim-colored **self-drilling screws (H1030)** at **4"** on center.

Cope the top of trim flush with the end of the roof panel. Cope the bottom vertical leg flush with the wall corner trim. Fasten to the end caps as shown using **(11) pop rivets (H1100)** and **(6)** colored **self-tapping screws (H1050)**.

Fasten to the wall panel with trim-colored **self-tapping screws (H1050)** at **12"** on center.

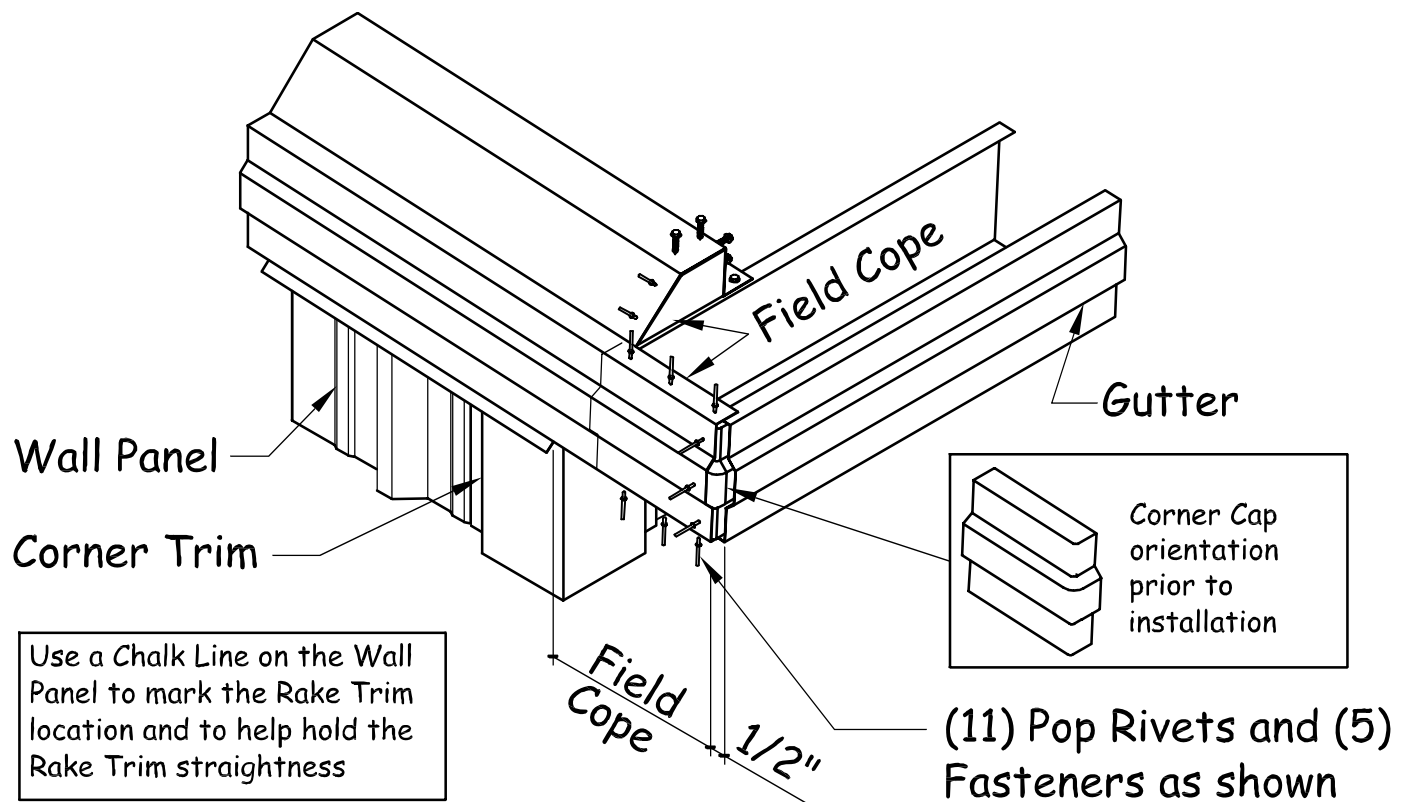

4.8 RAKE TRIM TERMINATION AT HIGH EAVE OR RIDGE

If your building has a ridge, stop the rake trim flush with the end of the roof panel (5 1/4" from ridge centerline).

If your building is a single slope, extend the rake trim 1" past the face of the wall corner trim. Field cope the vertical leg flush to the wall corner trim.

Field cope the upper section of the trim back 1". Additionally, cope the sloped face back 2 7/8", at an angle to match the 2 7/8" coped top and back legs.

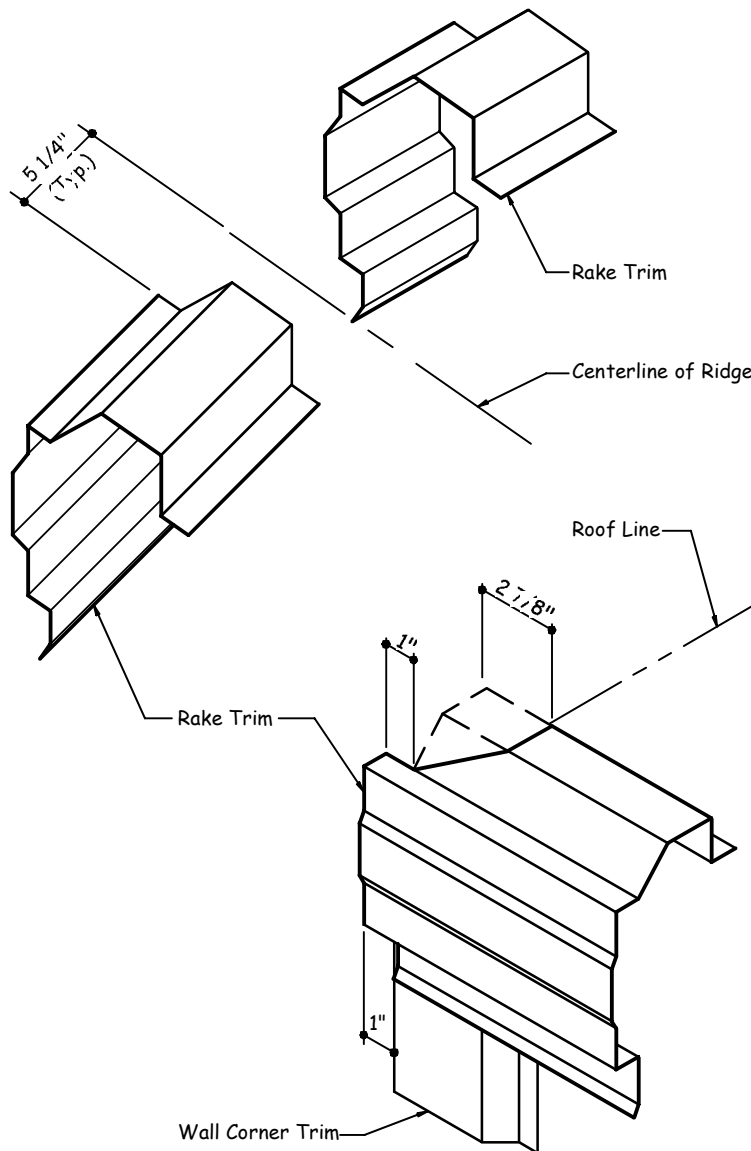

4.9 **PEAK BOX INSTALLATION AT RIDGE CAP**

Peak box and peak transition installation instructions for **DIE-FORMED** ridge cap (RGA__) and **PRESS-BROKE** ridge cap (RGG__):

Die-formed ridge cap must be installed **prior** to installing plastic peak parts. Go to Section 3.10 for die-formed ridge cap installation.

For press-broke ridge cap, the plastic peak parts must be installed **before** the press-broke ridge cap. After peak parts are installed refer to Section 4.10 and 4.11 to install the press-broke ridge cap.

Apply **polyurethane tube caulk (H3152)** around the perimeter of the **plastic peak cap (H4100 or H4110)**. Position the peak cap over the rake trim and fasten to the rake trim with (8) **pop rivets (H1100)**.

Apply **polyurethane tube caulk (H3152)** to the back edge and both sides of the peak transition piece. Also apply tube caulk to the sloped leg of the peak cap.

Center the **plastic transition piece (H4030 or H4040)** over the peak cap and fasten through the face with (6) colored **self-tapping screws (H1050)**, and through the back leg into the roof panel with (4) trim-colored **self-tapping screws (H1050)**.

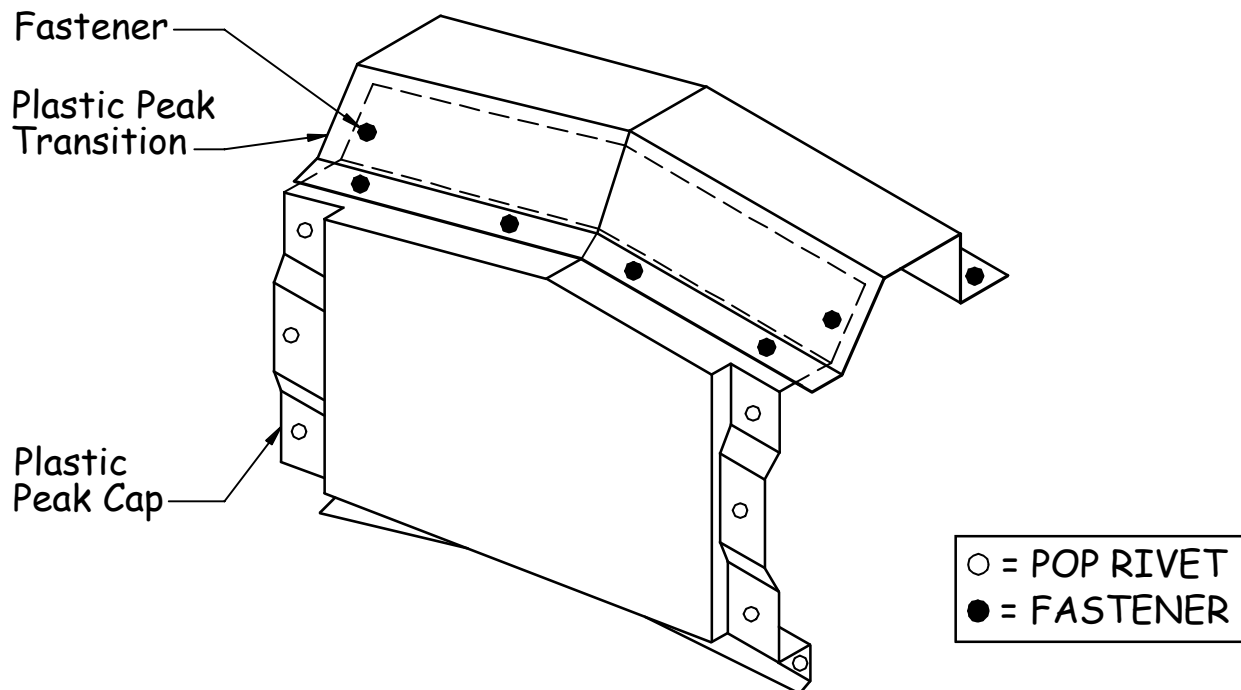

4.10 PRESS-BROKE RIDGE CAP INSTALLATION AT PEAK BOX

See the Erection Drawings for the **press-broke ridge cap part number (RGG__)**.

Start the ridge cap by field notching the first piece of ridge cap as shown in **FIG. A**. Bend all tabs 90°.

Before installing the ridge cap, apply $\frac{3}{4}$ " **tape mastic (H3000)** continuously across the top and bottom of the outside closures the full length of the roof. Place the tape mastic and closures 7" from the ridge centerline.

Place a bead of **polyurethane tube caulk (H3152)** on Tabs "B" and "C" (typical 4 places). Center the ridge cap over the closures and tightly against the back of the rake trim. Fasten Tab "B" to the back of the plastic peak part/rake

trim with (1) trim colored **self-tapping screw (H1050)**. Place a bead of **polyurethane tube caulk (H3152)** between Tab "A" and Tab "B" and fasten through the tabs and into the plastic peak part with (1) trim colored **self-tapping screw (H1050)**. Fasten Tab "C" into the plastic peak part with (2) trim colored **self-tapping screws (H1050)**. Repeat these steps for the other side of the ridge cap.

Fasten the ridge cap at the **HIGH** ribs with trim-colored **self-tapping screws (H1050)** at 12" on center.

NOTE: THE RIDGE CAP MUST BE PROPERLY POSITIONED BEFORE TOUCHING THE MASTIC. REMOVE THE PAPER BACKING ON THE TOP OF THE CLOSURES ONLY AS WORK PROGRESSES. MASTIC CANNOT BE RE-USED.

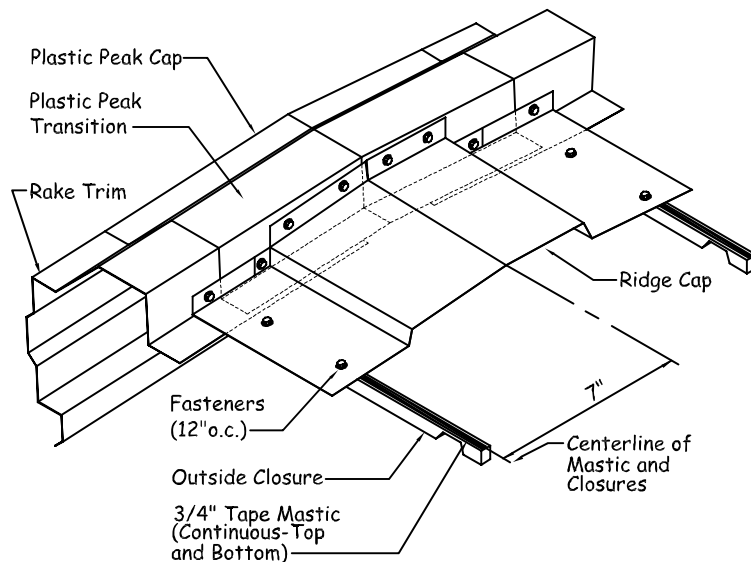
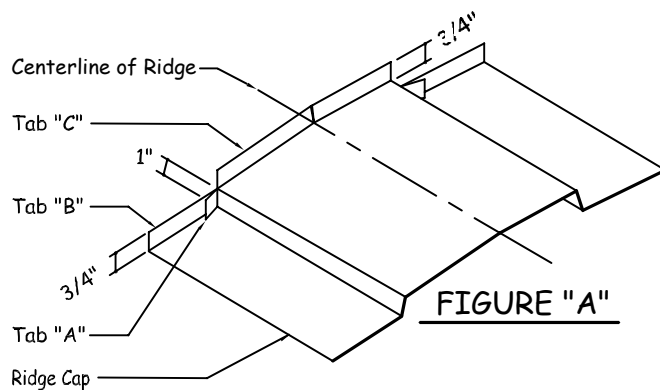

**4.11 PRESS-BROKE RIDGE CAP LAP
DETAIL**

DO NOT use fasteners at ridge cap laps. Also, DO NOT lap the ridge caps at the roof panel high ribs.

The ridge cap is to be lapped 4", utilizing (2) beads of butyl tube caulk (H3151). Also apply butyl tube caulk on the tape mastic (as shown).

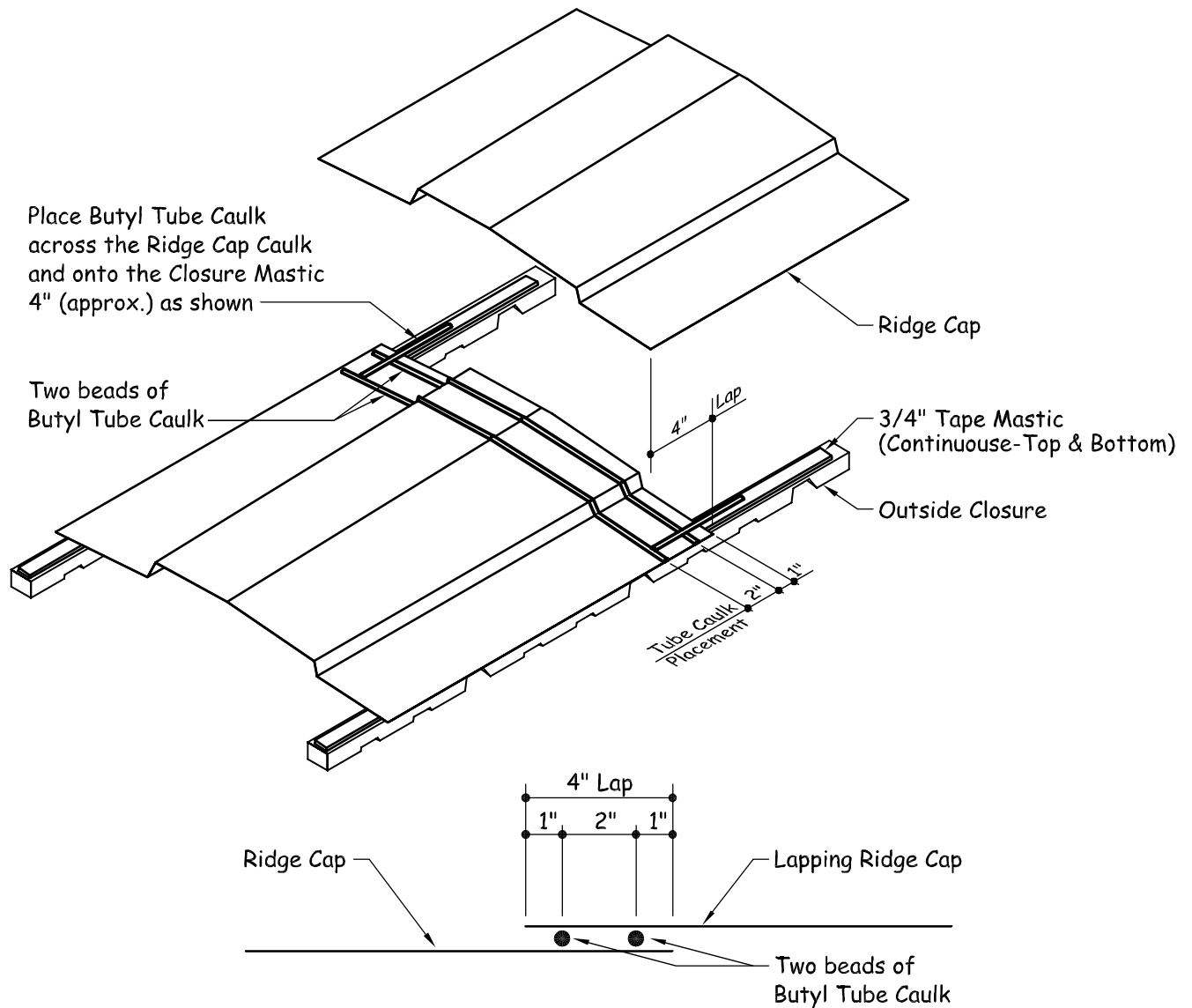

RIDGE CAP LAP TUBE CAULK PLACEMENT DETAIL

4.12 HIGH EAVE TRIM INSTALLATION

Before installing the **high eave trim** (see erection drawing roof line trim details for part numbers), apply **polyurethane tube caulk (H3152)** around the perimeter of the **corner cap (H4000)** and slide it into the end of the rake trim leaving 1/2" exposed.

Apply **3/4" tape mastic (H3000)** continuously across the top and bottom of the closures the full length of the roof. Remove the paper backing on the mastic that is on top of the closures only as work progresses.

Lay the high eave trim over the mastic and closures and fasten at the panel **HIGH** ribs with

trim-colored **self-tapping screws (H1050)** at 12" on center. **NOTE: The trim must be properly positioned before touching the mastic. Mastic cannot be reused.**

Field cope the high eave trim the same as the rake trim, with an additional cut to form tab "A".

Fold the sloped face of the high eave trim over the sloped face of the rake trim. Caulk all around with **polyurethane tube caulk (H3152)** and then fasten with (3) pop rivets (**H1100**).

Fasten the high eave trim and the rake trim to the plastic corner cap with (7) **pop rivets (H1100)**. Fasten the top leg of trim with (6) trim-colored **self-tapping screws (H1060)**.

NOTE:

Field bend the top leg of the High Eave trim over the sloped leg of the Rake Trim and attach with (3) Pop Rivets.

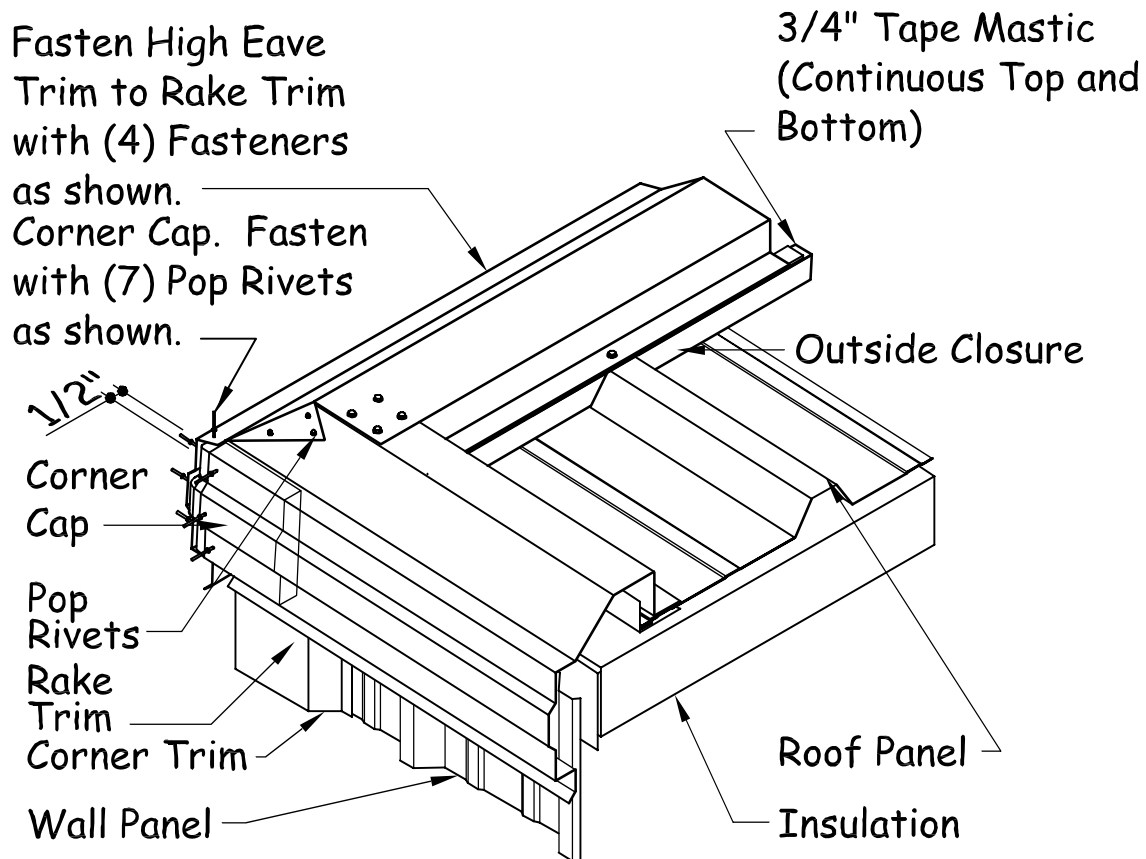

4.13 RAKE PARAPET TRIM INSTALLATION WITH AND WITHOUT GUTTER

Stop the gutter 1/2" short of the inside face of the parapet wall.

Apply **polyurethane tube caulk (H3152)** around the perimeter of the **corner cap (H4000)** and install it in the gutter, leaving 1/2" exposed at the end. Fasten with (10) **pop rivets (H1100)**.

Apply continuous **2 1/4" tape mastic (H3020)** to the bottom leg of the **rake parapet trim (RPA01)** and position it flush with the end of the roof panel.

NOTE: The trim **must** be properly positioned before touching the mastic to the roof panel. **Mastic cannot be reused!**

Fasten to the roof panel with **self-drilling screws (H1030)** at 4" on center. Apply **polyurethane tube caulk (H3152)** around the perimeter of the **rake parapet cap (*)** and slide it into place. Fasten with (9) trim-colored **self-tapping screws (H1050)**.

(*) RAKE PARAPET CAP PART NUMBERS:
RCB01-LEFT
RCBO2-RIGHT

If your building does not have gutter, these same instructions apply. However, you will not need the corner cap.

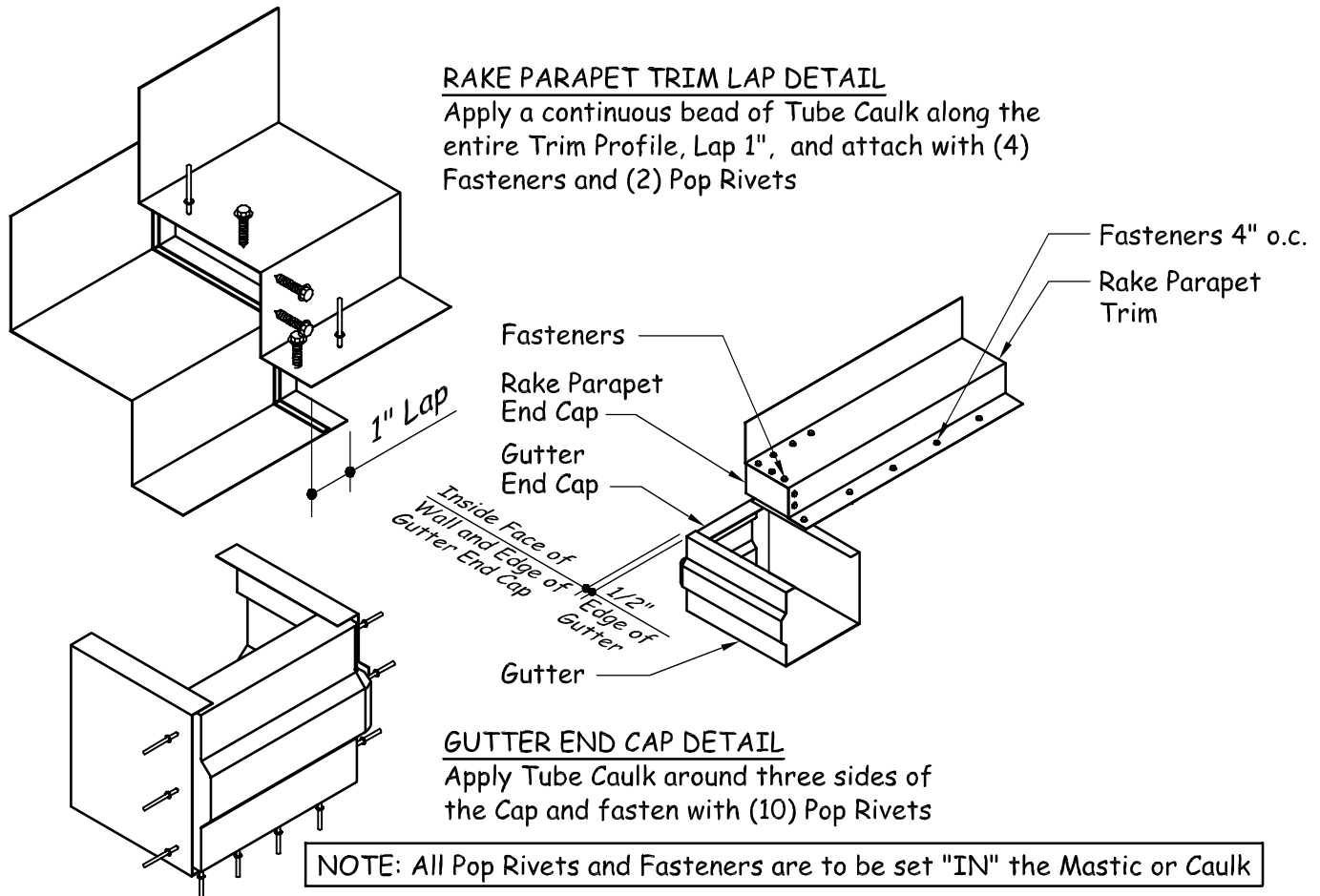

4.14 RAKE PARAPET TRIM TERMINATION AT DIE-FORMED RIDGE CAP

If your building has a ridge, stop the **rake parapet trim (RPA01)** flush with the end of the roof panel.

If your building is single slope, stop the **rake parapet trim (RPA01)** flush with the inside face of the parapet wall.

To install the **plastic peak transition piece (H4050 or H4060)** apply a generous bead of **polyurethane tube caulk (H3152)** to the rake parapet trim as shown. Center the transition piece over the ridge and fasten with (14) trim-colored **self-tapping screws (H1050)**.

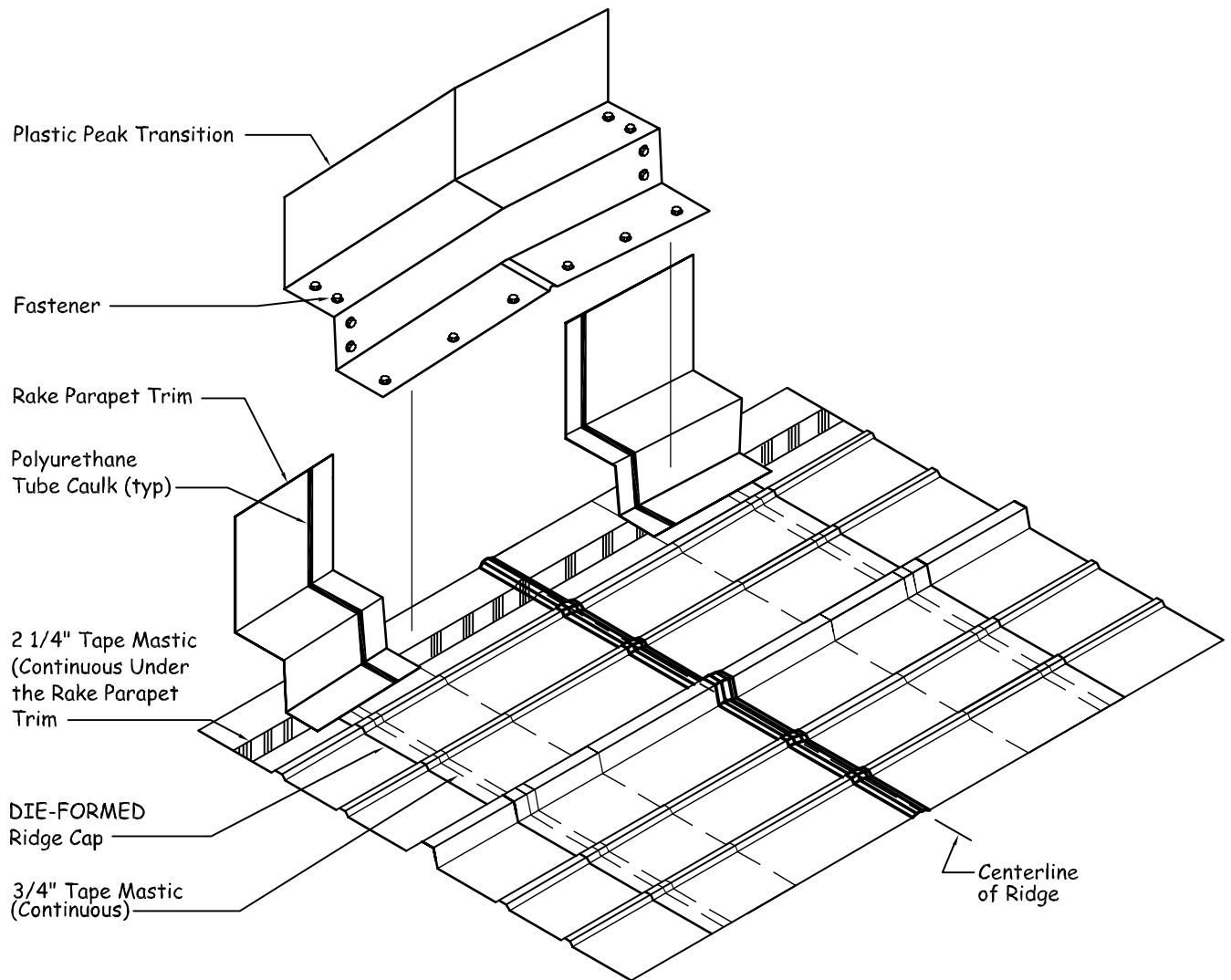

4.15 RAKE PARAPET TRIM TERMINATION AT PRESS-BROKE RIDGE CAP

If your building has a **ridge**, stop the **rake parapet trim (RPA01)** flush with the end of roof the panel.

If your building is a **single slope**, stop the **rake parapet trim (RPA01)** flush with the inside face of the parapet wall.

To install the **plastic peak transition piece (H4050 or H4060)** apply a generous bead of **polyurethane tube caulk (H3152)** to the rake parapet trim as shown under the plastic peak part. Center the transition piece over the ridge and fasten with **(8) trim colored self-tapping screws (H1050)**.

Start the ridge cap by field notching the first piece of ridge cap as shown in **FIG. A**. Bend all tabs 90°.

Before installing the ridge cap, apply **3/4" tape mastic (H3000)** continuously across the top and bottom of the outside closures the full length of the roof. Place the tape mastic and closures 7" from the ridge centerline.

Place a bead of **polyurethane tube caulk (H3152)** on Tabs "B" and "C" (typical 4 places). Center the ridge cap over the closures and tightly against the back of the rake trim. Fasten Tab "B" to the back of the plastic peak part/rake trim with (1) trim colored **self-tapping screw (H1050)**. Place a bead of **polyurethane tube caulk (H3152)** between Tab "A" and Tab "B" and fasten through the tabs and into the plastic peak part with (1) trim colored **self-tapping screw (H1050)**. Fasten Tab "C" into the plastic peak part with (2) trim colored **self-tapping screws (H1050)**. Repeat these steps for the other side of the ridge cap.

Fasten the ridge cap at the **HIGH** ribs with trim-colored **self-tapping screws (H1050)** at 12" on center.

NOTE: THE RIDGE CAP MUST BE PROPERLY POSITIONED BEFORE TOUCHING THE MASTIC. REMOVE THE PAPER BACKING ON THE TOP OF THE CLOSURES ONLY AS WORK PROGRESSES. MASTIC CANNOT BE RE-USED.

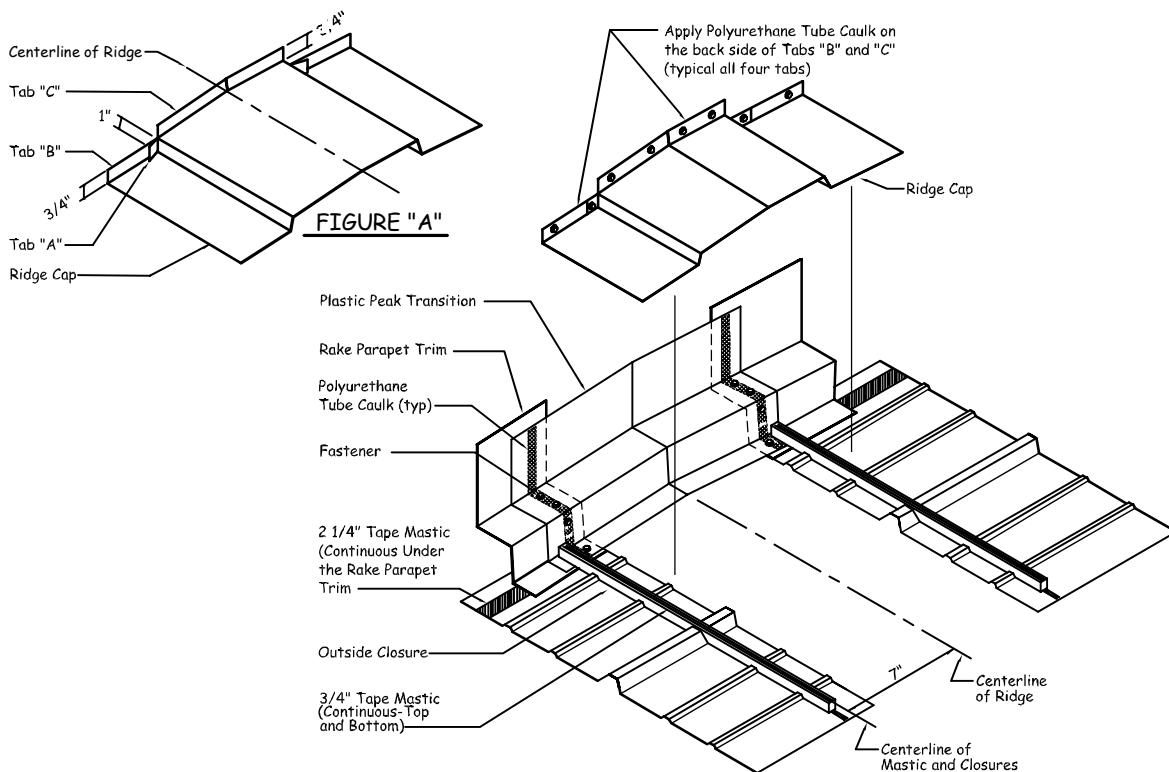

4.16 **HIGH EAVE PARAPET TRIM INSTALLATION**

Temporarily place the high eave parapet trim in position to determine the correct location of the outside closures. The closures should be 2" away from the low end of the trim as shown below.

Apply 3/4" tape mastic (H3000) continuously across the top and bottom of the closures the full length of the roof.

STOP! Field mitering of the high eave parapet trim is required before installing.

Field cut and form tabs "A", "B", "C", and "D" as shown below.

Apply a piece of 2 1/4" tape mastic (H3020) to the rake parapet trim as shown. Next, apply a bead of polyurethane tube caulk (H3152) on

Tab "A". Place the high eave parapet trim (HP_01) over the closures and tightly against the rake parapet trim and fasten with (4) trim colored self-trapping screws (H1050).

Apply a bead of polyurethane tube caulk (H3152) between Tab "A" and Tab "B" and fasten Tab "B" with (1) trim colored self-trapping screw (H1050). Next, apply a bead of polyurethane tube caulk (H3152) between Tab "C" and Tab "D" and fasten Tab "D" with (1) trim colored self-tapping screw (H1050).

Fasten the high eave parapet trim at the panel **HIGH** ribs with trim colored self-tapping screws (H1050) at 12" on center.

NOTE: The trim **must** be properly positioned before touching the mastic. Remove paper backing only as work progresses. **Mastic cannot be reused.**

